

STEERING SYSTEM

CONTENTS

STEERING SYSTEM	ST- 2	STEERING LINKAGE	ST-21
STEERING WHEEL AND COLUMN	ST- 3	SERVICE DATA AND	
STEERING WHEEL	ST- 3	SPECIFICATIONS	ST-23
STEERING LOCK	ST- 3	GENERAL SPECIFICATIONS	ST-23
STEERING COLUMN (Model 160 series)	ST- 4	INSPECTION AND ADJUSTMENT	ST-23
MANUAL STEERING GEAR (Model :		TIGHTENING TORQUE	ST-24
VRB70L) —Model 160 series—	ST- 6	TROUBLE DIAGNOSES AND	
MANUAL STEERING GEAR (Model :		CORRECTIONS	ST-25
VRB70L) —Model 61 series—	ST-10	SPECIAL SERVICE TOOLS	ST-27
POWER STEERING GEAR (Model :			
I.P.S. 56L) AND OIL PUMP	ST-12		

STEERING SYSTEM

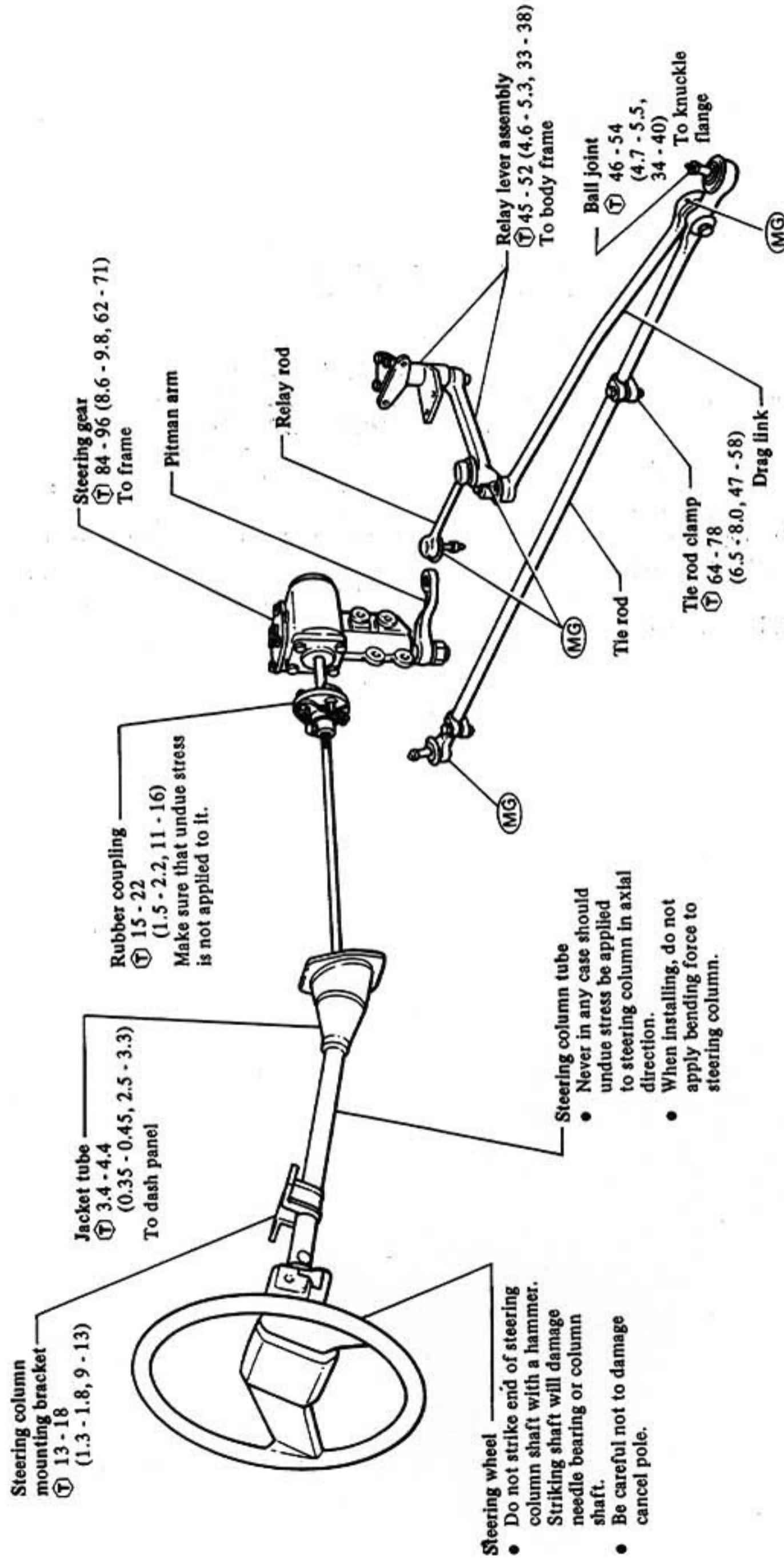

STEERING WHEEL AND COLUMN

STEERING WHEEL

REMOVAL

1. Disconnect battery ground cable.
2. Remove horn pad and steering wheel nut.

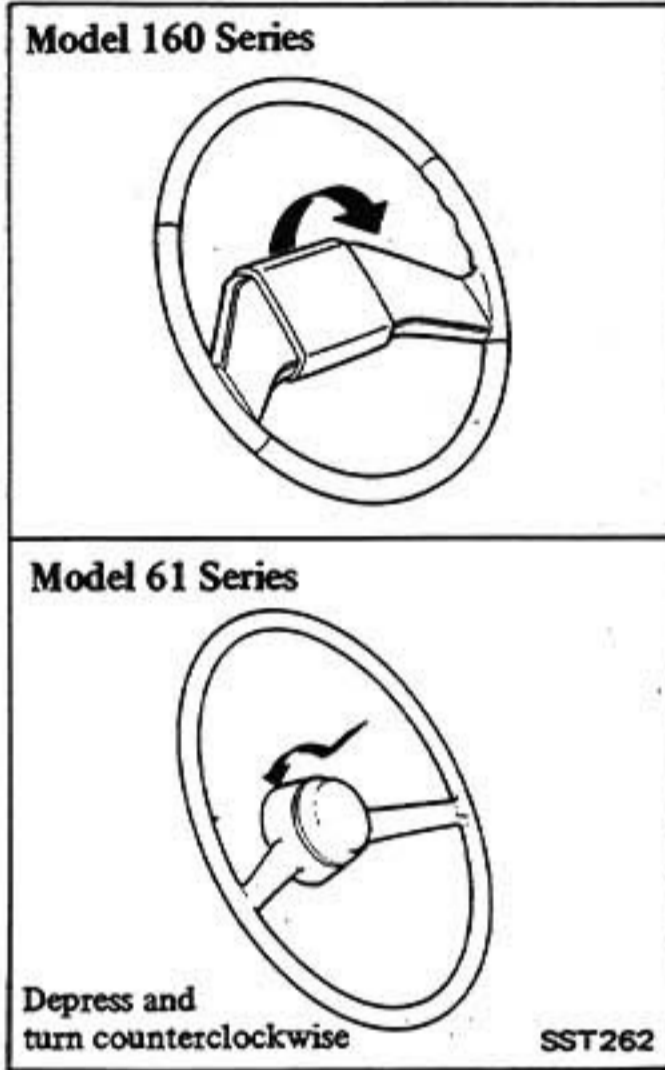

3. Remove steering wheel using Tool.

CAUTION:

Do not strike end of steering column shaft with a hammer. Striking shaft will damage bearing or column shaft.

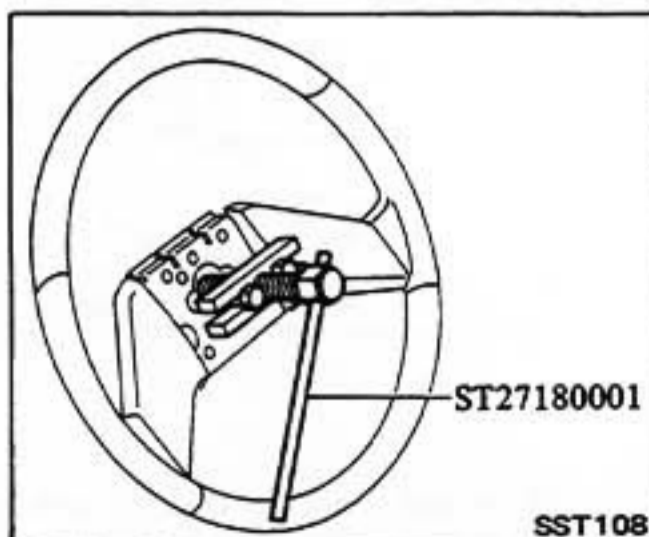

INSTALLATION

Install steering wheel in the reverse order of removal. Observe the following instructions.

1. Apply grease to sliding portions.

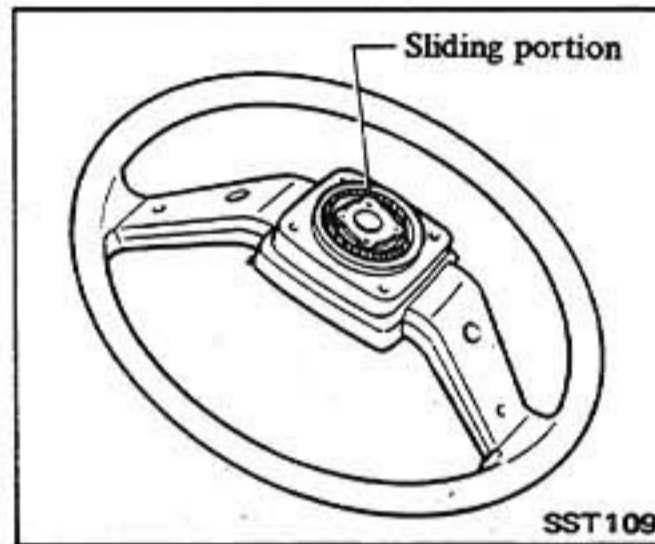

2. Install steering wheel on column shaft in a straight-ahead position.

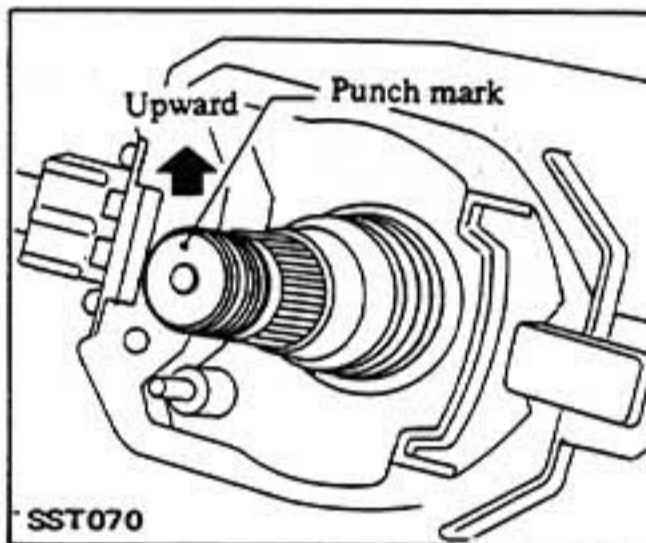

3. Tighten steering wheel nut.

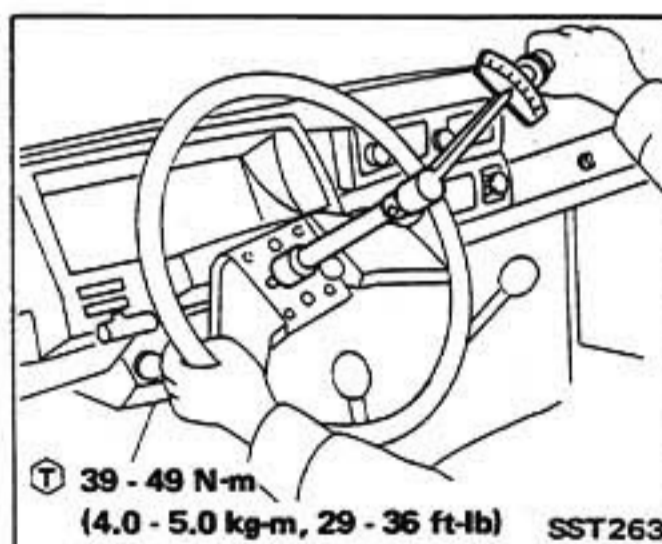

4. After installing steering wheel, turn it clockwise and counterclockwise, checking for catch or drag. Also check horn operation.

STEERING LOCK

REMOVAL

Before removing steering lock, disconnect battery ground cable.

1. Remove steering column shell cover.
2. Break self-shear type screws with a drill or other appropriate tool.
3. Remove screws and disconnect steering lock.

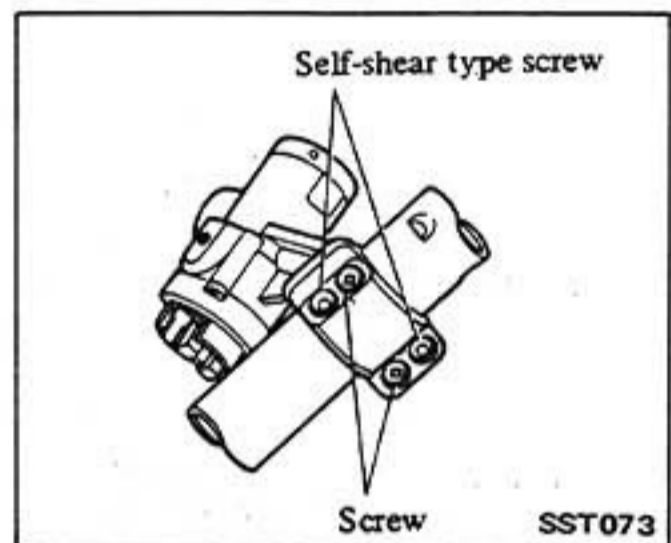

INSTALLATION

1. Align steering lock hole in steering column tube with mating portion of steering lock.
2. Install screws and self-shear type screws and then cut off self-shear type screw heads.

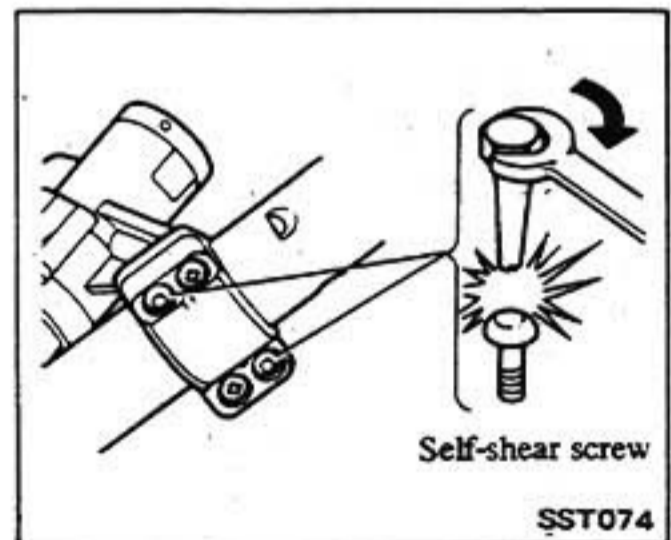

STEERING COLUMN (Model 160 series)

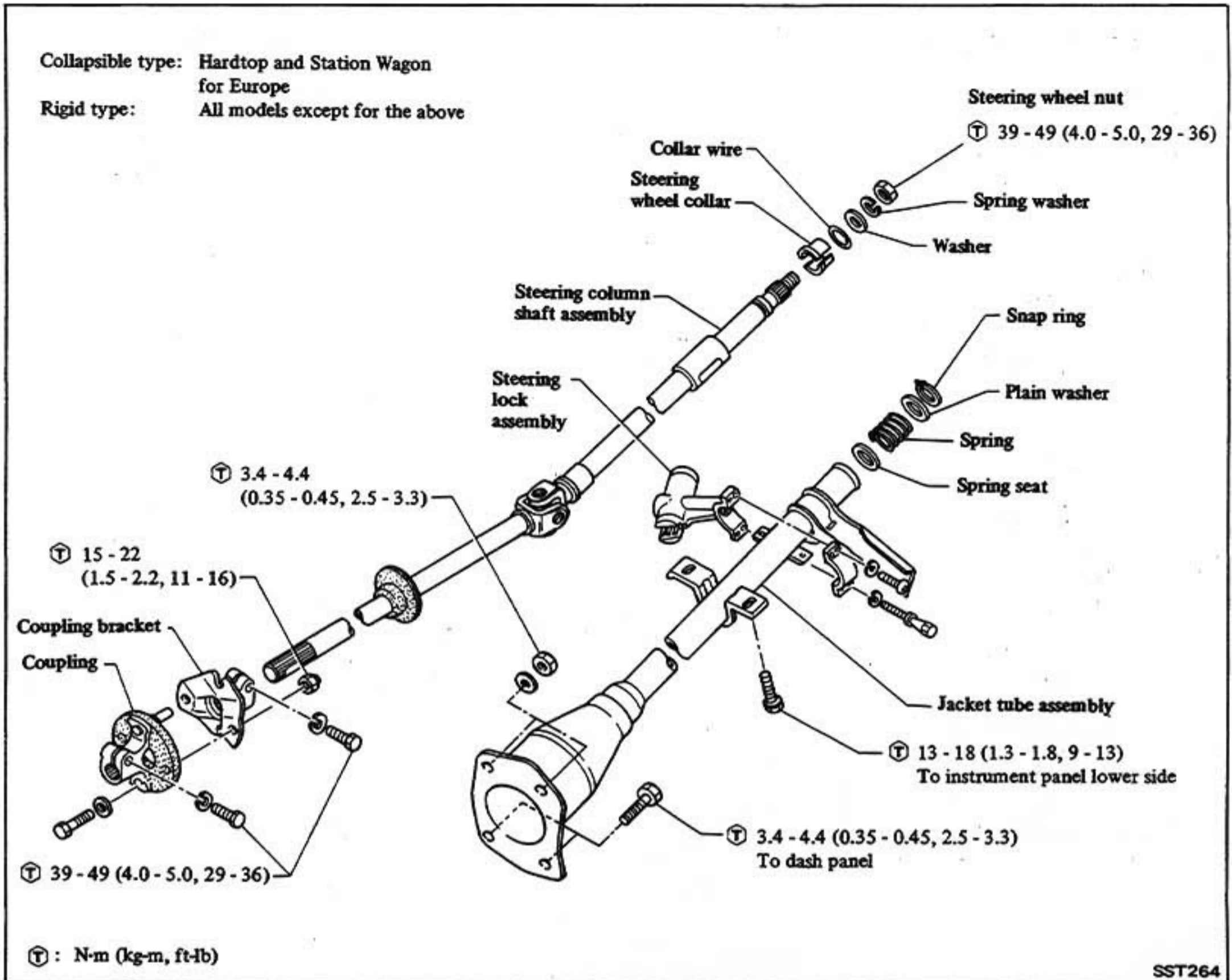

REMOVAL

1. Remove bolt securing column shaft and rubber coupling.

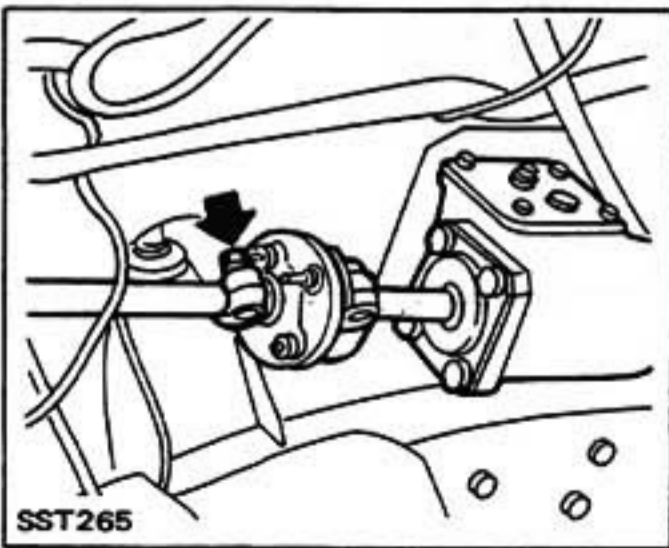

2. Remove steering wheel. Refer to Steering Wheel.

3. Remove steering column shell covers.

4. Remove combination switch assembly.

Refer to Section EL.

5. Remove jacket tube bracket from dash panel.

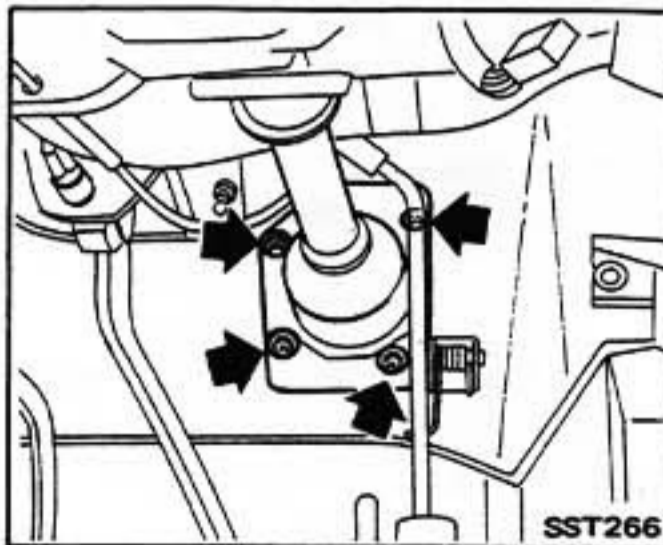

6. Remove column mounting bracket.

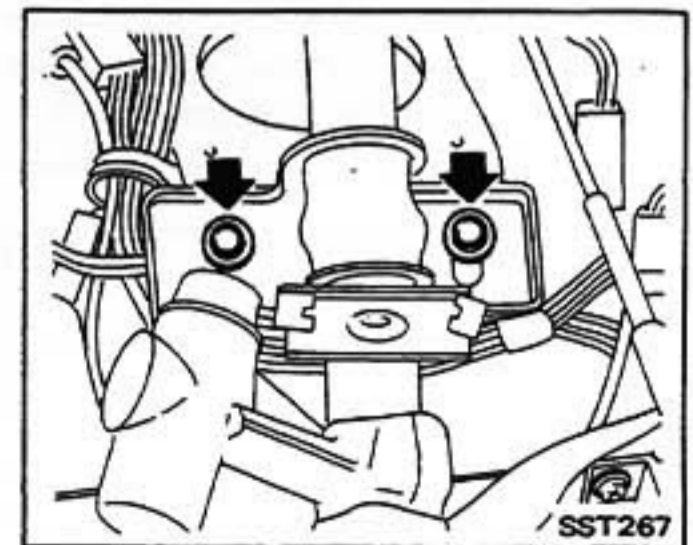

7. Draw out steering column assembly from room side.

INSTALLATION

Install steering column in reverse order of removal.

1. Set wheels in a straight-ahead position.
2. Fit steering column assembly on to worm shaft.

Carefully install so that punch mark at top end of column shaft faces upward.

3. After sliding jacket tube bracket to dash panel, tighten nuts to retain it.

Ⓣ : Jacket tube bracket to dash panel

3.4 - 4.4 N·m
(0.35 - 0.45 kg·m,
2.5 - 3.3 ft·lb)

4. Tighten column mounting bracket temporarily.
5. Tighten column shaft securing bolts temporarily to support upper side of steering column assembly.
6. Tighten column shaft securing bolts and then tighten column mounting bracket securing bolts.

Ⓣ : Rubber coupling to column shaft

39 - 49 N·m
(4.0 - 5.0 kg·m,
29 - 36 ft·lb)

Column mounting bracket

13 - 18 N·m
(1.3 - 1.8 kg·m,
9 - 13 ft·lb)

CAUTION:

- a. Make sure that any undue stress is not applied to rubber coupling.
- b. To avoid damaging bolt or serrations, align groove in worm shaft with bolt hole in rubber coupling.

7. Install steering wheel. Refer to **Steering Wheel**.

8. After installation, make sure that steering wheel turns smoothly.

DISASSEMBLY

1. Remove rubber coupling assembly.

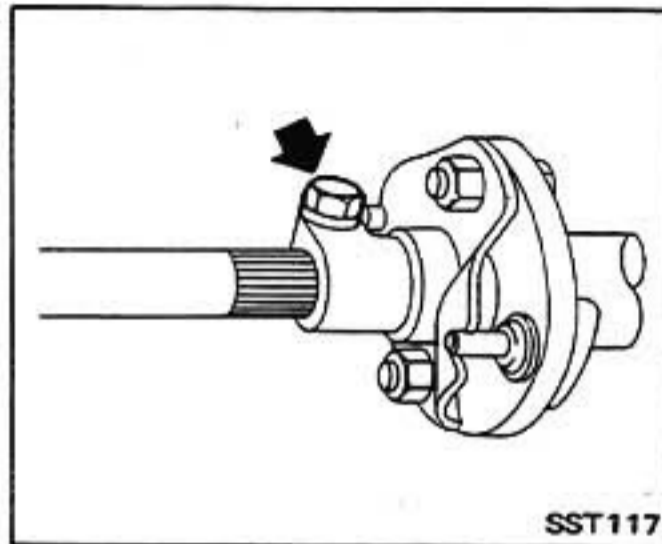

2. Remove steering lock assembly. Refer to **Steering Lock** for removal.
3. Compress steering column spring with wires.

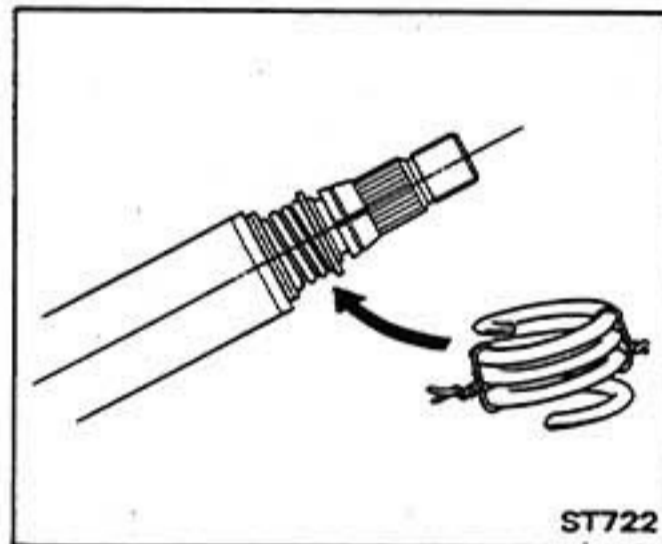

4. Remove collar fixing wire, steering wheel fixing collar, snap ring, plain washer, steering column spring and spring seat.

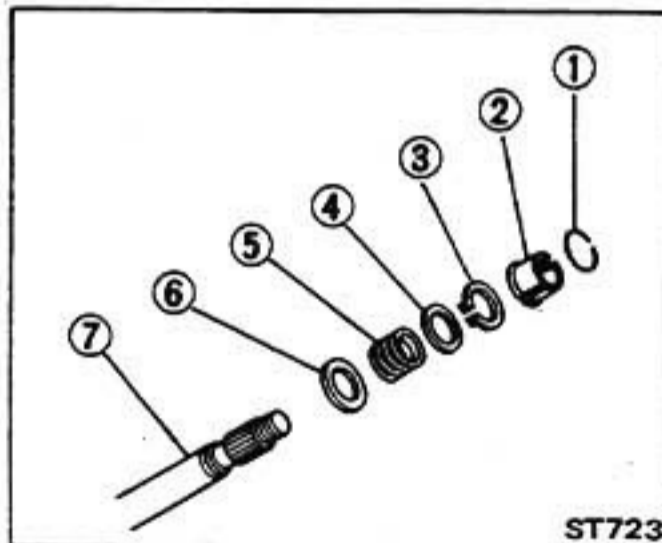

- 1 Collar wire
- 2 Steering wheel collar
- 3 Snap ring
- 4 Plain washer
- 5 Steering column spring
- 6 Spring seat
- 7 Steering column assembly

5. Pull column shaft out.

CAUTION:

Be careful not to damage upper and lower bearings into column tube.

ASSEMBLY

Assemble steering column in the reverse order of disassembly. Observe the following notes.

Apply recommended multi-purpose grease to column bearings, spring, and other sliding parts.

CAUTION:

- Be careful to prevent interference with remote control lever bracket.
- Be careful not to give impact force or abnormally strong force in axial direction to steering column shaft.
- Snap ring for column shaft should not be reused.

INSPECTION

When steering wheel will not turn smoothly, check the steering column for the following matters and replace malfunctioning parts.

1. Check column bearing for damage or unsmoothness. If so, lubricate with recommended multi-purpose grease or replace with a new one as jacket tube assembly.
2. Check jacket tube for deformation or breakage, and replace if necessary.
3. Check column spring, and replace if damaged or weakened.

DISASSEMBLY

Before disassembling by hand, make sure external is clean and free from dust and dirt, and thoroughly drain gear fluid by removing filler plug.

1. Place steering gear in a vise using Tool KV48100301 in place.
2. Set worm gear in a straight-ahead position.

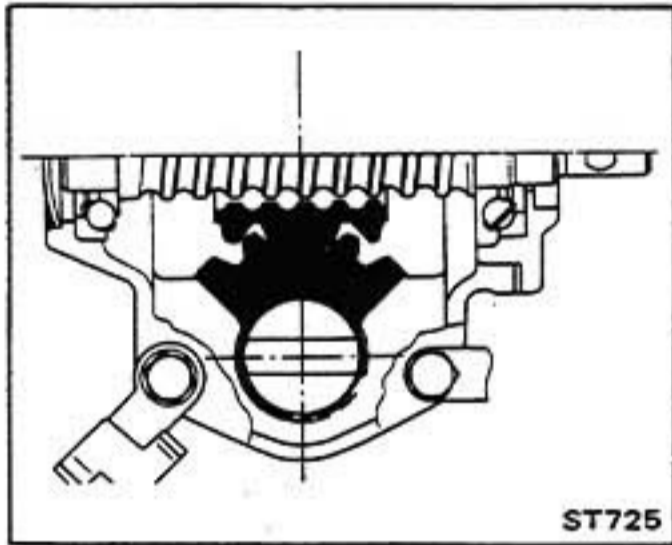

3. Remove sector shaft cover fixing bolts.

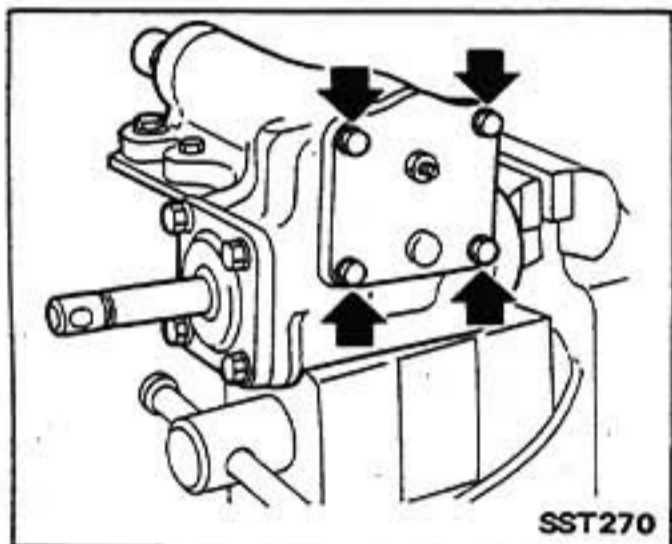

4. Remove sector shaft with sector shaft cover.

CAUTION:

- a. When pulling sector shaft out, be careful not to damage oil seal or associated parts.
- b. Set worm gear in a straight-ahead position.
- c. Do not remove sector shaft bearing from steering gear housing. If necessary, replace gear housing assembly.

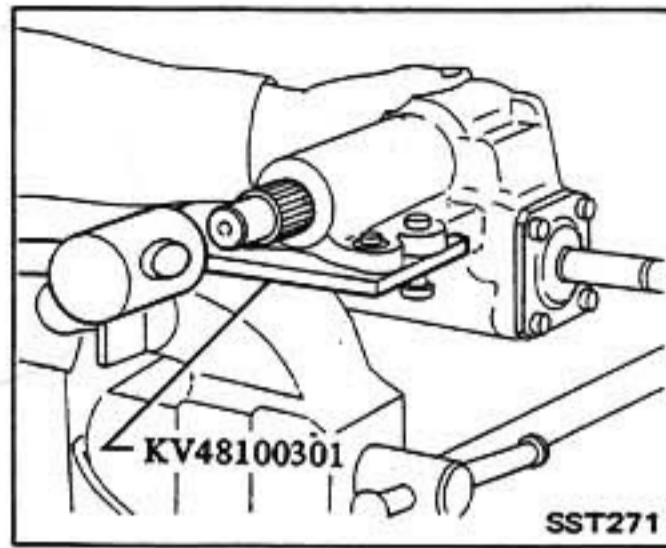

5. Remove sector shaft cover from sector shaft.
6. Remove sector shaft oil seal, if necessary.

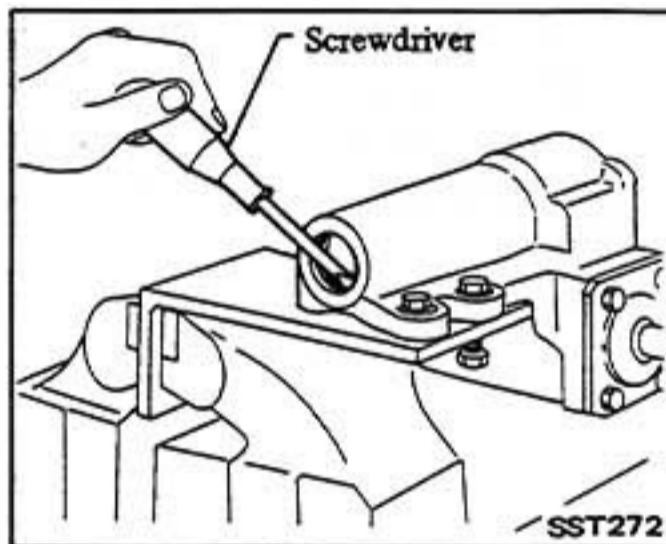

7. Remove rear cover.

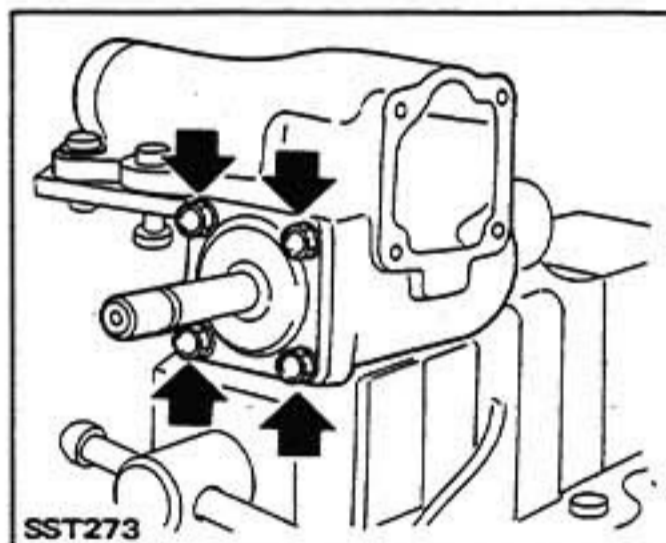

8. Draw out worm gear with worm bearing.

CAUTION:

- a. Be careful not to allow ball nut to run down to either end of worm. Ends of ball guides will be damaged if nut is rotated until it stops at end of worm.
- b. Do not detach ball nut from worm shaft assembly. If necessary, replace entire unit as an assembly.

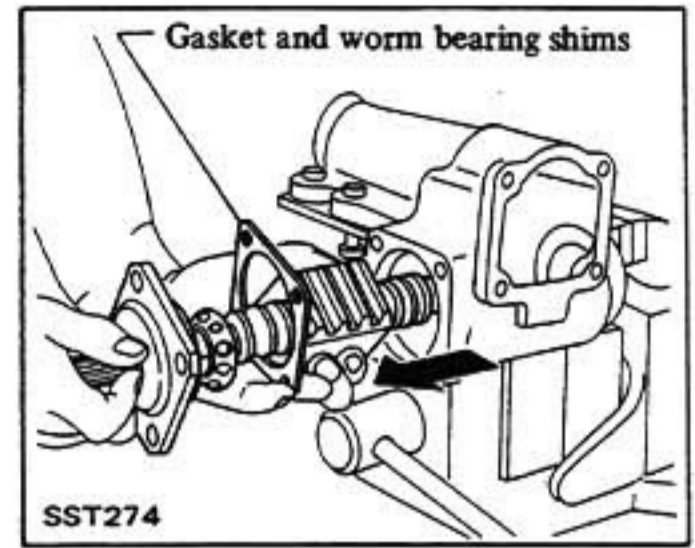

9. Remove oil seal from rear cover. Once removed, oil seal must not be used again.

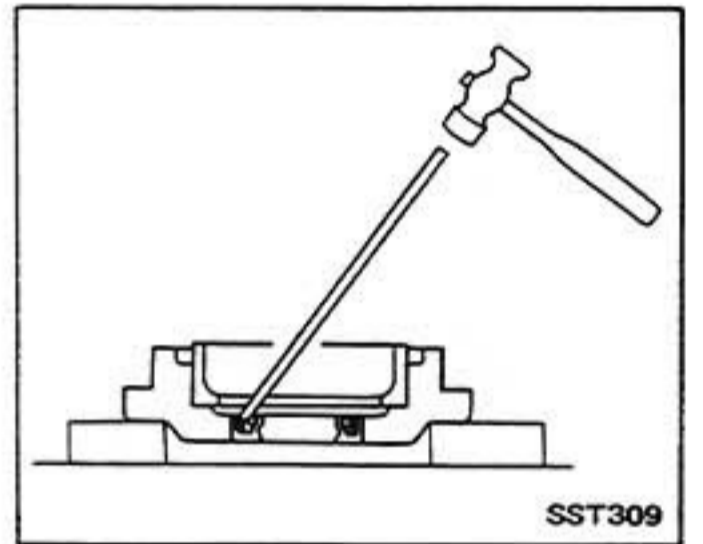

ASSEMBLY AND ADJUSTMENT

- Before assembling and adjusting by hand, make sure each part is clean and lubricate with gear fluid.
- Fill space between sealing lips of new sector shaft and adjusting plug oil seals with recommended multi-purpose grease.

Worm bearing preload

1. Fit worm gear assembly with worm bearing in gear housing.

2. Install rear cover on gear housing with gasket and worm bearing shims.

Standard shim thickness:
1.0 mm (0.039 in)

Available worm bearing shims:
Refer to S.D.S.

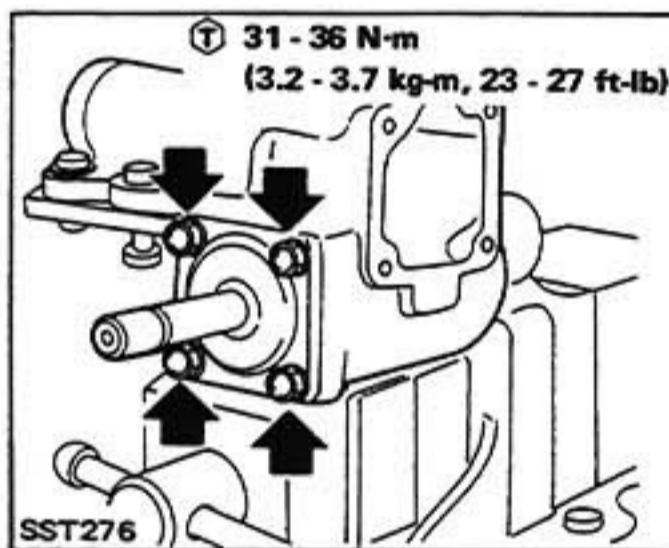
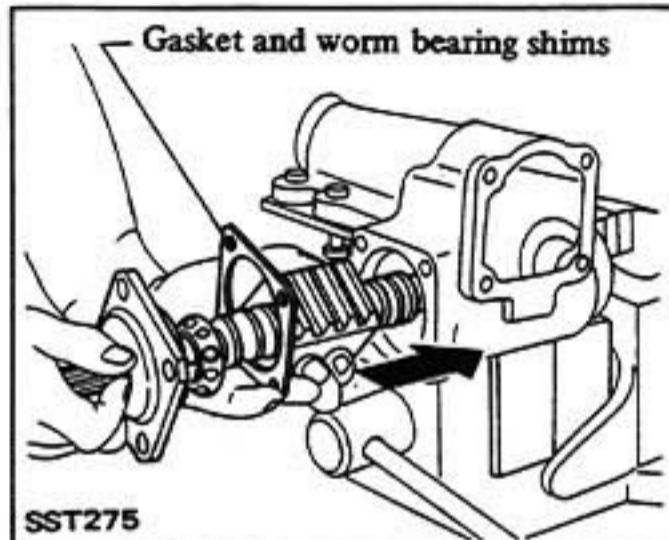

3. Adjust worm bearing preload using Tools.

- Rotate worm shaft a few turns in both directions to correctly settle worm bearing and measure preload.
- When adjusting worm bearing preload, add or remove shims until correct adjustment is achieved.

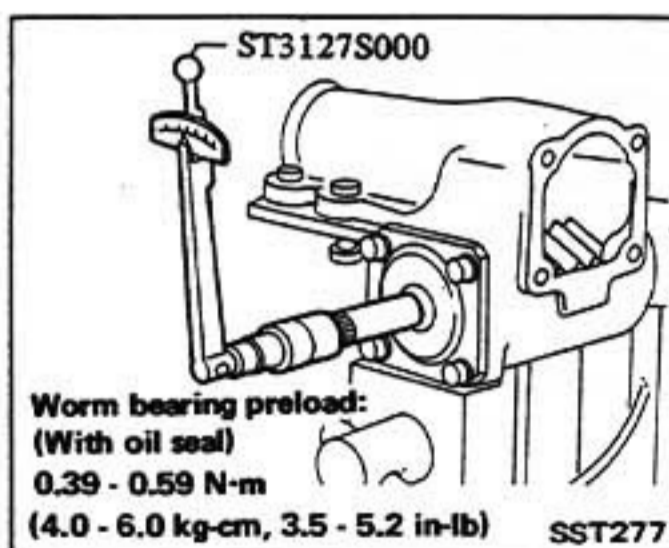

Sector shaft end play

Select suitable adjusting shim and adjust end play between sector shaft and adjusting screw.

Sector shaft adjusting screw shims:
Refer to S.D.S.

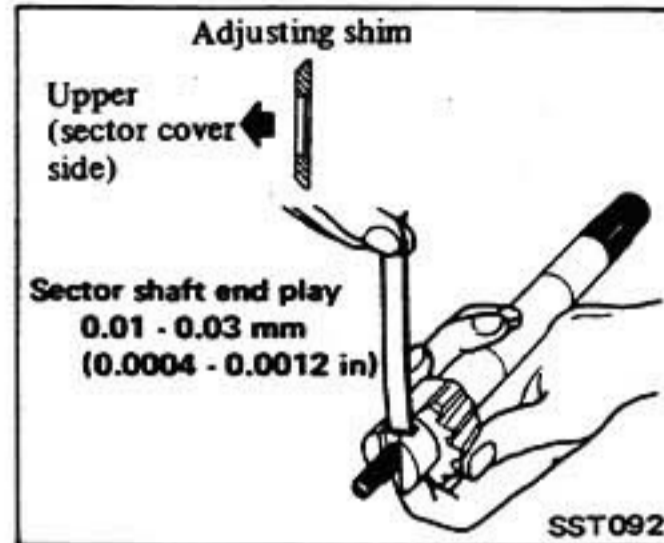

Steering gear preload

1. Press oil seal to steering gear housing using Tool.

Before pressing oil seal, coat seal contacting face of oil seal with gear fluid.

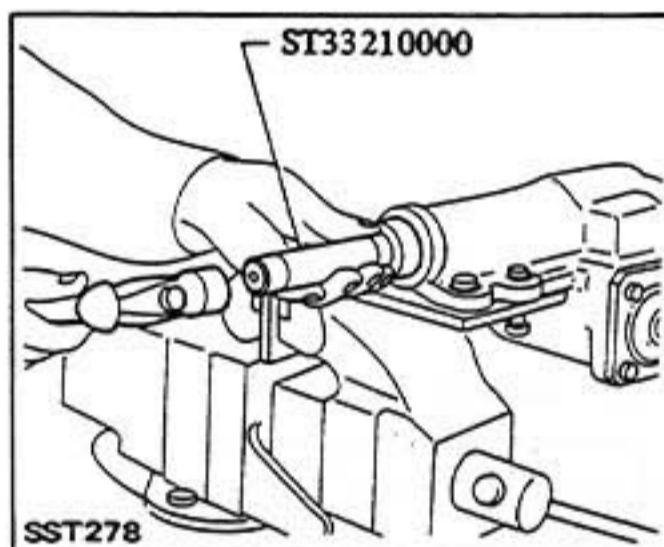

2. Install sector cover on adjusting screw with sector shaft.



3. Set worm gear in a straight-ahead position.

4. Insert sector shaft and sector cover assembly with gasket into gear housing.

Carefully insert sector shaft in place, using care not to scratch oil seal.

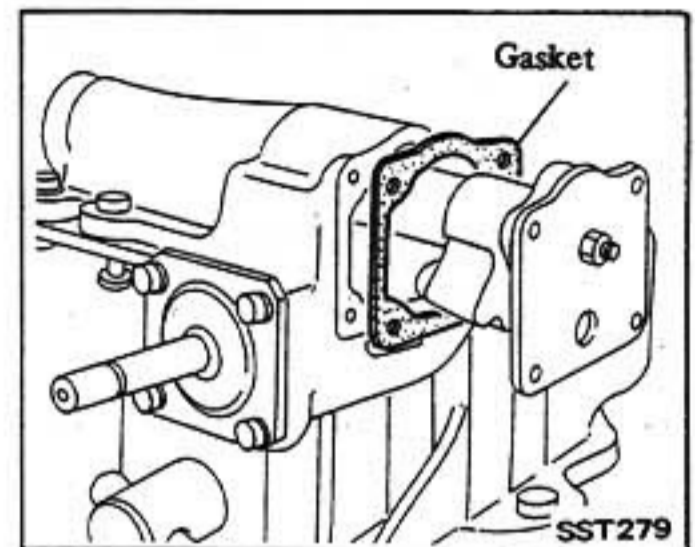

5. Tighten sector cover to gear housing.

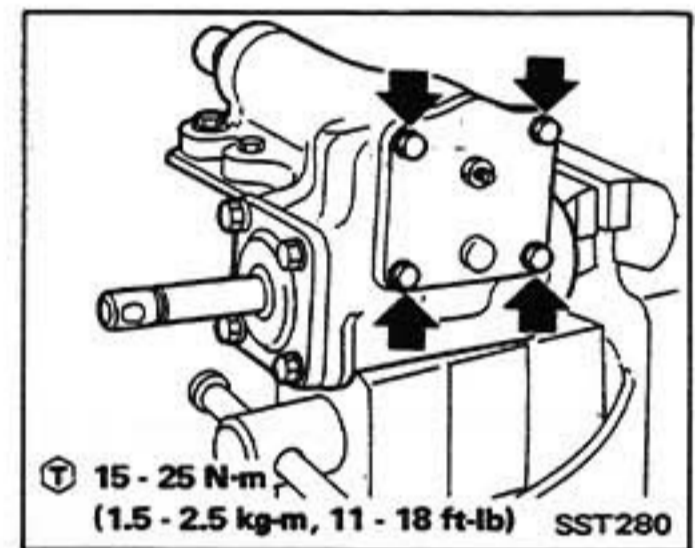

6. Adjust backlash as shown in illustration.

Rotate worm gear a few turns in both directions to settle down steering gear and in straight-ahead position, and then measure backlash at gear arm top end.

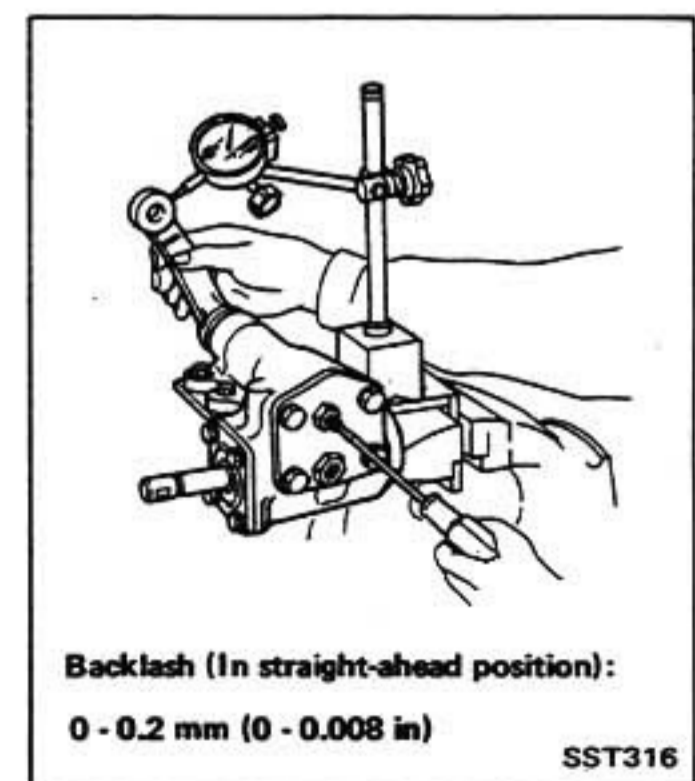

7. Measure total gear preload in straight-ahead position.

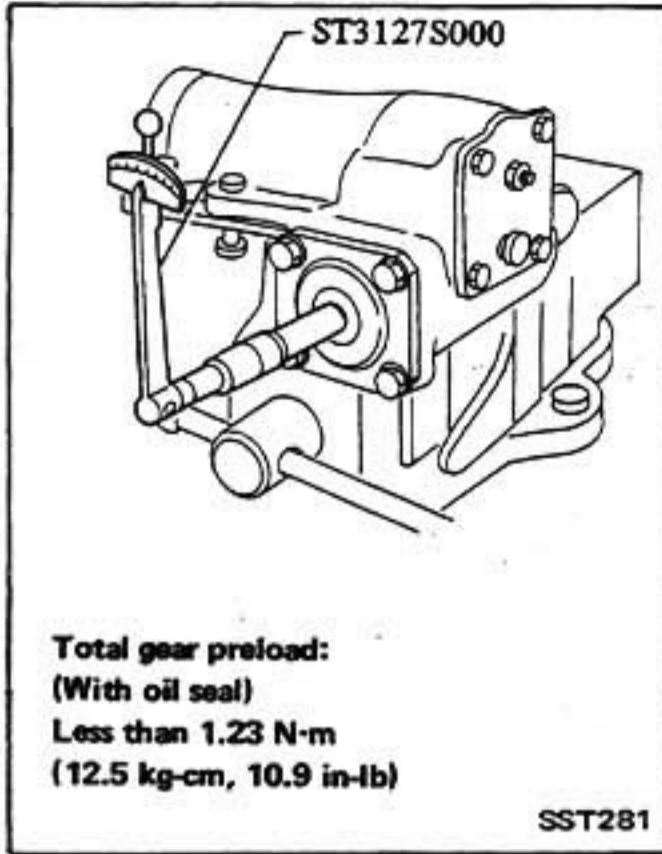

INSPECTION

Wash clean all the disassembled parts in solvent and check for condition.

Sector shaft

1. Check gear tooth surface for pitting, burrs, cracks or any other damage, and replace if necessary.

2. Check sector shaft for distortion on its serration, and replace if necessary. Also check gear housing for deformation.

Steering worm assembly

1. Inspect ball nut gear tooth surface, and replace if pitting, burrs, wear or any other damage is found.
2. Ball nut must rotate smoothly on worm gear. If found too tight, assembly should be replaced.

Check rotation of ball nut as follows:

(1) Move ball nut to either end of worm gear, and gradually stand worm shaft and ball nut assembly until ball nut moves downward on worm gear under its own weight.

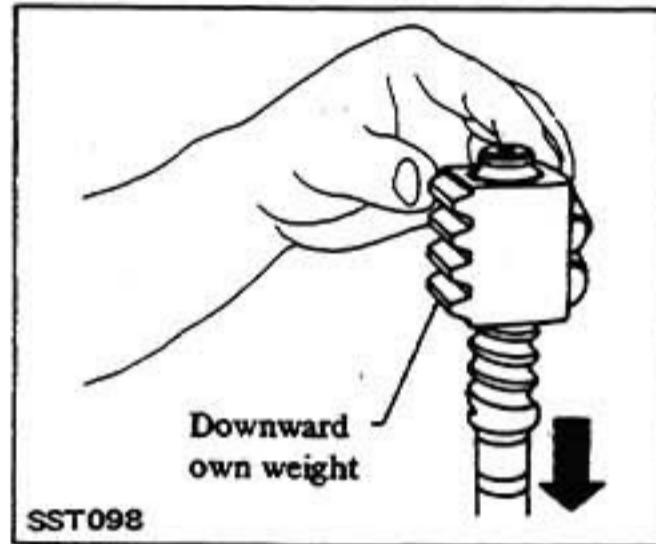

(2) If ball nut does not move freely over entire stroke, replace assembly.

Be careful not to damage ball nut guide tube while check is being made.

CAUTION:

Be careful not to allow ball nut to run down to either end of worm.

Bearing

1. Inspect worm bearing for wear, pitting or any other damage. Replace as required.

When replacing worm bearing, replace it as a set of bearing and outer race.

2. If sector shaft needle bearings are worn or damaged, replace as an assembly of gear housing and bearings.

Oil seals

Discard any oil seal which has once been removed. Replace oil seal if sealing lip is deformed or cracked. Also discard oil seal if spring is fatigued or dislocated.

MANUAL STEERING GEAR (Model : VRB70L) —Model 61 series—

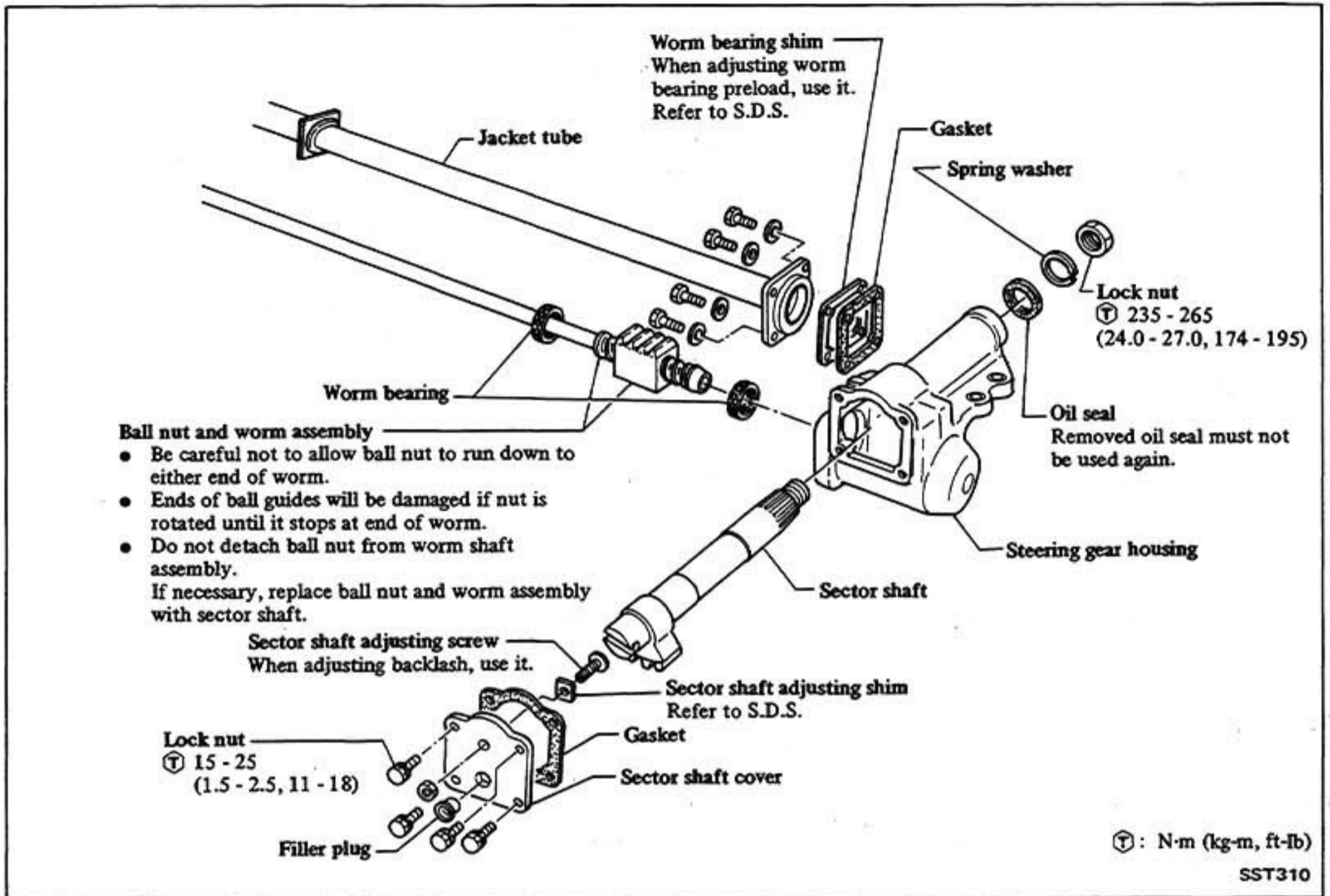

REMOVAL AND INSTALLATION

1. Remove following parts.
 - Steering wheel
 - Steering shell cover
 - Combination switch
 - Steering column mounting bracket
2. Loosen combination meter cover.
3. Jack up front of vehicle and support it on safety stands.
4. Block rear wheels with chocks.
5. Remove following parts.
 - Harness connectors at alternator and water temperature sensor

- Alternator
- Radiator shroud attaching bolts

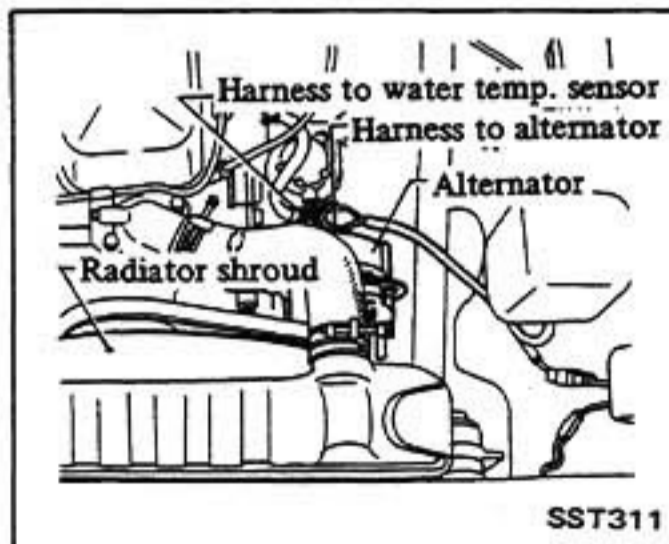

6. Remove pitman arm.

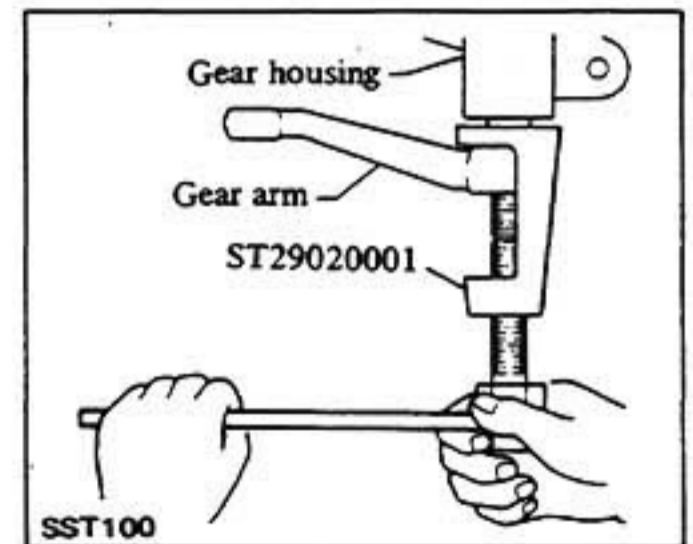

7. Remove bolts securing gear box.

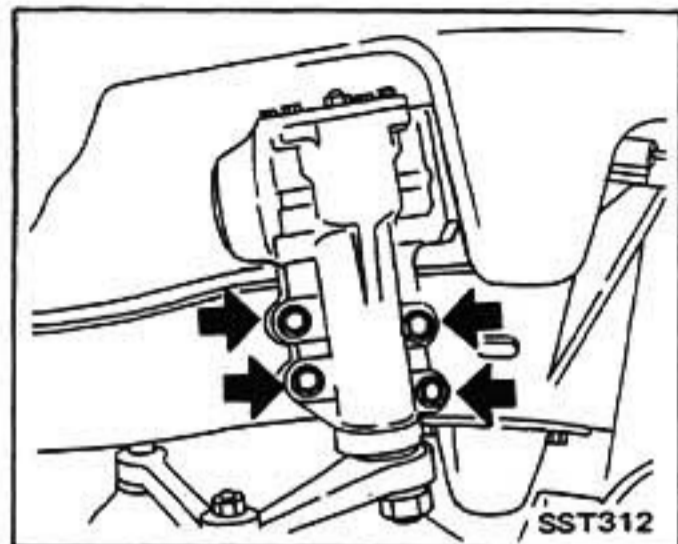

8. After removing steering lock, extract steering gear from under vehicle body.

DISASSEMBLY

Before disassembling steering gear,

make sure external is clean and free from dust and dirt, and thoroughly drain gear fluid by removing filler plug.

For disassembly, refer to Manual Steering Gear (Model: VRB70L) –Model 160 Series–. However, note the following additional instruction.

- Placing steering gear in a vise.

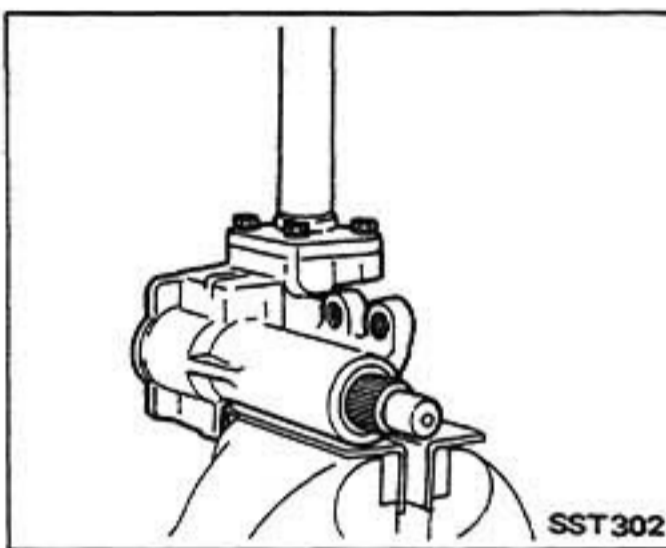

ASSEMBLY AND ADJUSTMENT

- Before assembling and adjusting, make sure each part is clean and lubricate with gear fluid.
- Fill space between sealing lips of new sector shaft and rear cover oil seals with recommended multi-purpose grease.

Refer to Manual Steering Gear (Model: VRB70L) –Model 160 Series–.

INSPECTION

Refer to Manual Steering Gear (Model: VRB70L) –Model 160 Series–.

POWER STEERING GEAR (Model : I.P.S. 56L) AND OIL PUMP

DESCRIPTION

Power steering system

The power steering gear is licensed by ZF company in West Germany.

The integral power steering unit is a gear housing into which a control valve (2-spool valve type) and power cylinder are built compactly. The major

components are as follows:

- Oil pump
- Power steering gear
- Oil piping

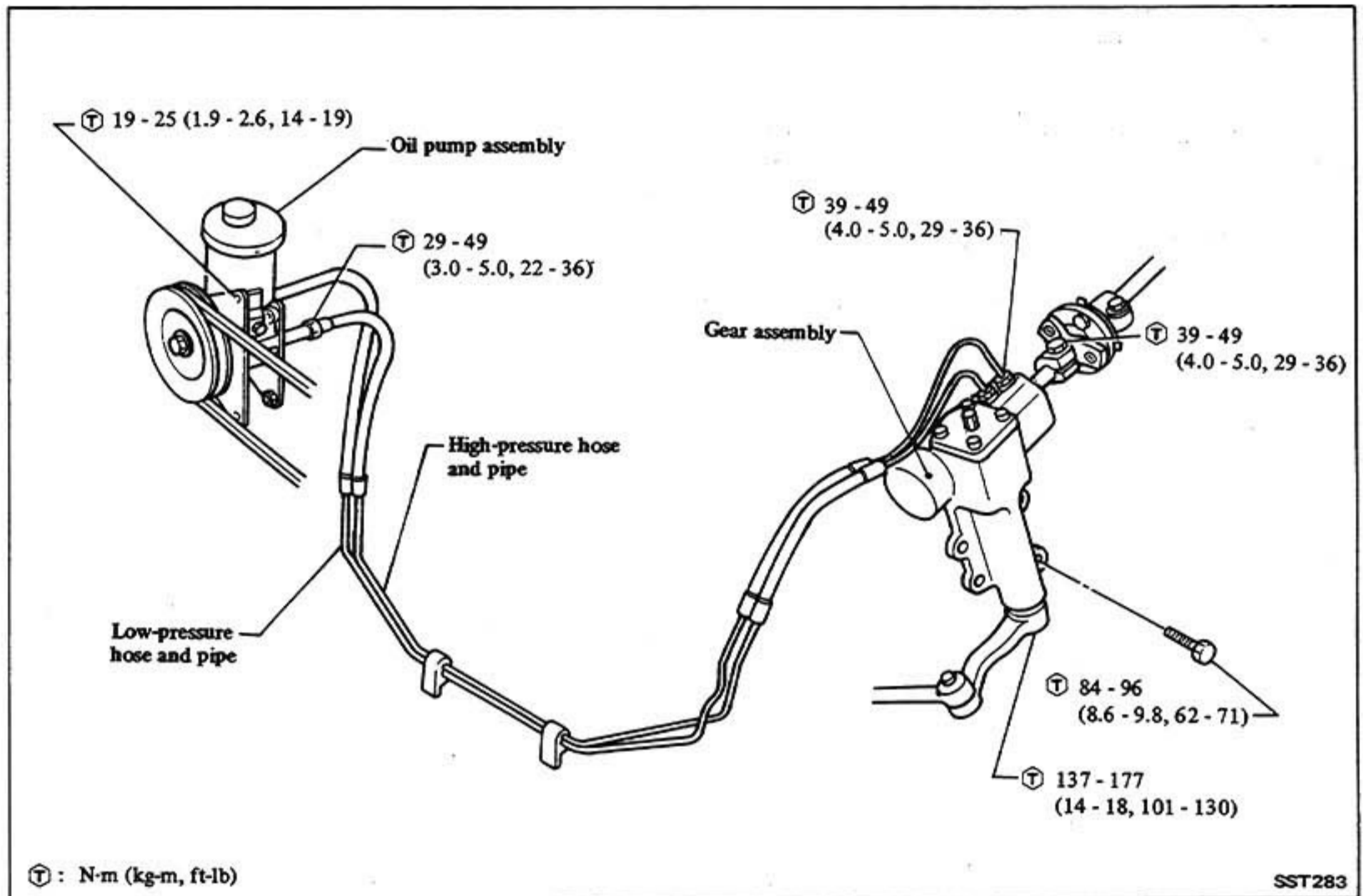

Power steering gear

The integral power steering gear is an accurate oil pressure mechanism. In disassembling it, be careful to keep dust, iron powder and other foreign particles out of the gear housing.

Only the sealing parts of the gear assembly can be replaced. The remaining parts must be replaced as an gear assembly.

CAUTION:

- a. The parts which can be disassembled are strongly restricted, and never disassemble other parts than the specified ones. If parts not indicated in the manual are also disassembled, replace the assembly instead of reassembling those parts.
- b. Disassembly of integral power steering gear should be performed in a place as clean as possible, although a dust preventing device is not required.

- c. Should disassembly of integral power steering gear remain unfinished for any reason, indicate it as "Half Disassembled" and cover parts with a clean cover.
- d. Hands should be cleaned immediately before disassembly.
- e. Do not use a rag. Be sure to use nylon or paper cloth.
- f. Be sure to follow procedures and cautions indicated in the Service Manual.

STEERING SYSTEM – Power Steering Gear (Model: I.P.S. 56L) and Oil Pump

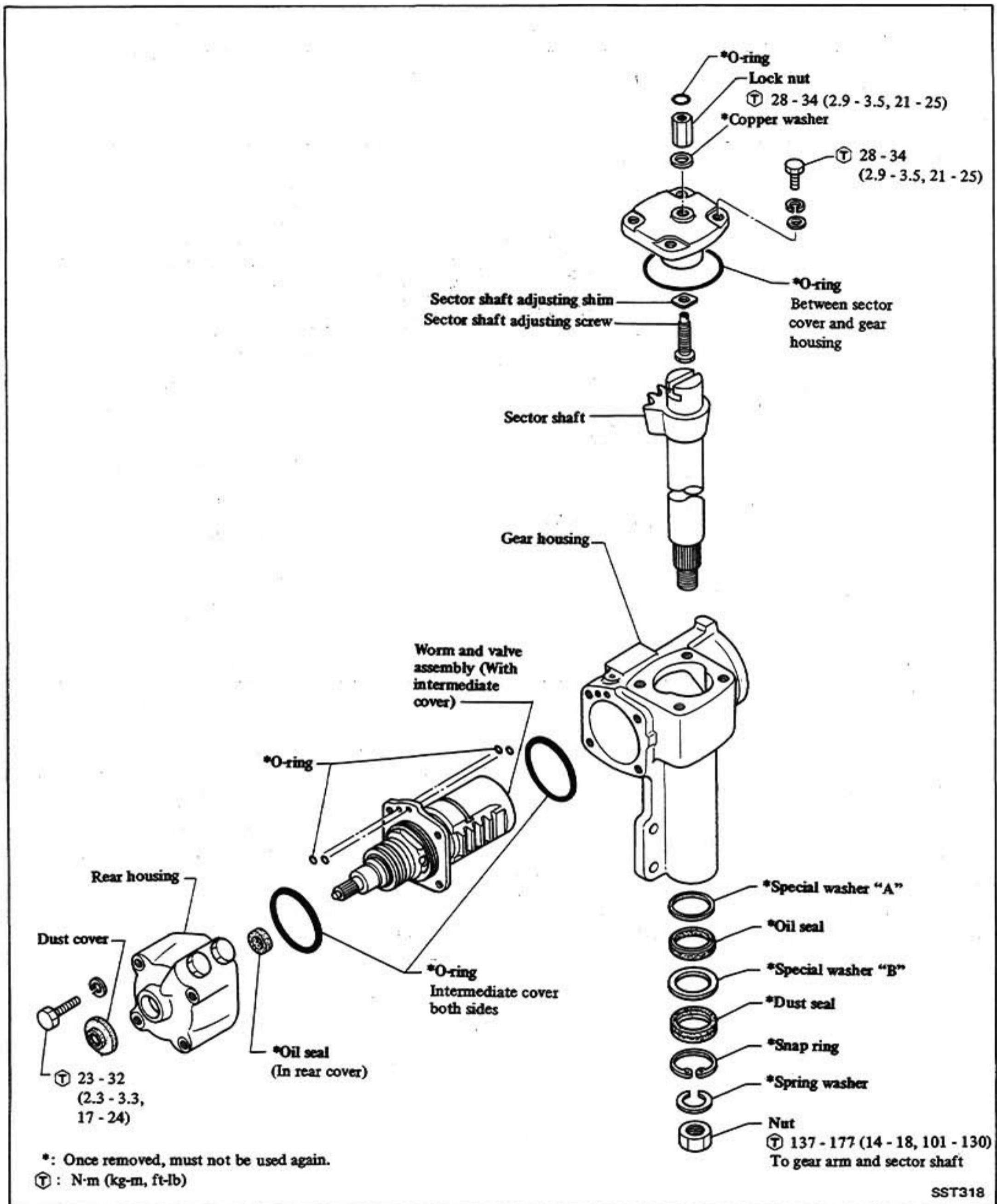

Oil pump

Malfunctioning (Replace as an oil pump assembly).

REMOVAL

Before removing, clean exteriors of gear housing and oil pump with steam and dry with compressed air.

Steering gear

Hose to gear housing
Ⓣ 39 - 49
(4.0 - 5.0, 29 - 36)

Rubber coupling to stub shaft
Ⓣ 39 - 49 (4.0 - 5.0, 29 - 36)

Gear housing to body
Ⓣ 84 - 96 (8.6 - 9.8, 62 - 71)

Sector shaft to gear arm
Ⓣ 137 - 177 (14 - 18, 101 - 130)

- Plug openings of gear housing, and securely locate hose connectors at a position higher than oil pump and cover with rag.
- Be extremely careful to prevent entry of foreign matter into hoses through connectors.

● Remove gear arm.

ST29020001

- Install gear arm
Align four grooves of gear arm serrations with four projections of sector shaft serrations, and install and tighten lock washer and nut.

Ⓣ : N·m (kg·m, ft·lb)
▲ : Removing points

SST284

Oil pump and each hose

1. Turn belt adjusting bolt counter-clockwise.

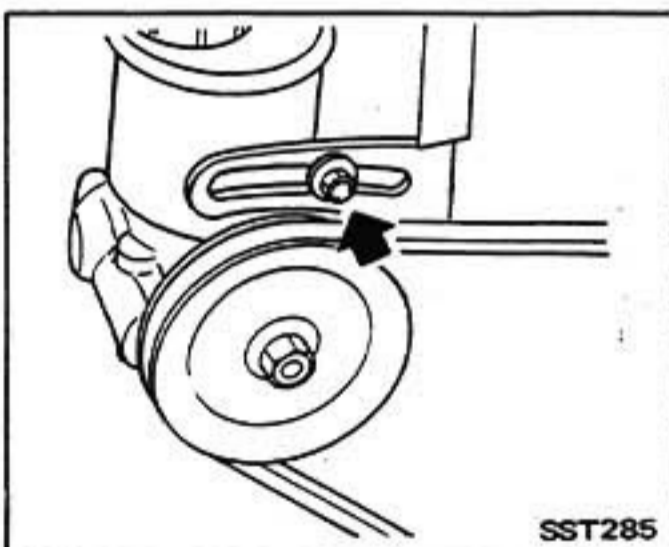

2. Remove oil pump belt.
3. Loosen (not remove) hoses at pump.

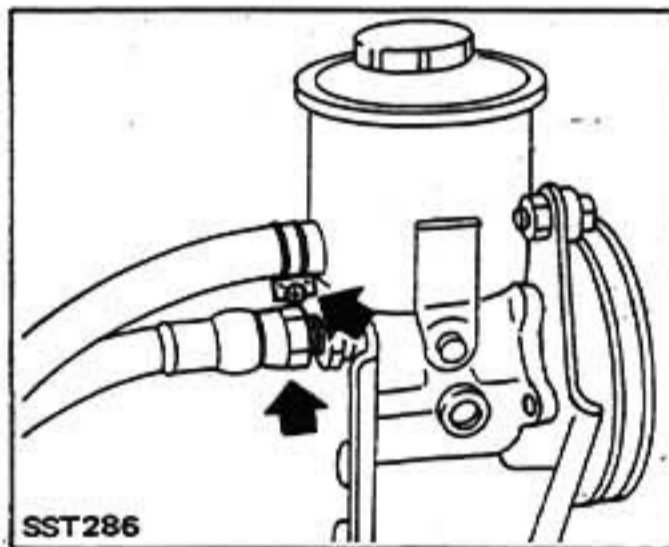

4. Remove oil pump.

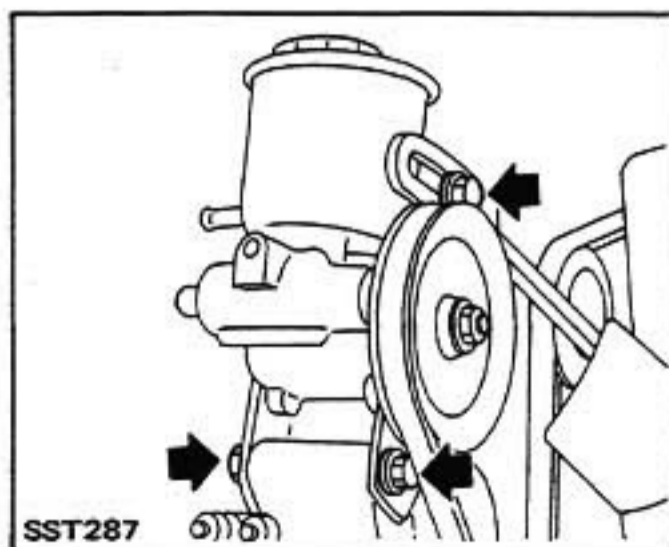

5. Disconnect hoses from pump.
6. Remove oil pump brackets and other brackets from engine.
7. Unfasten hose clamps, and remove hoses from suspension crossmember.

INSTALLATION AND ADJUSTMENT

Install steering gear in the reverse order of removal.

Fluid level

1. Check fluid level in reservoir, observing dipstick when fluid is cold.

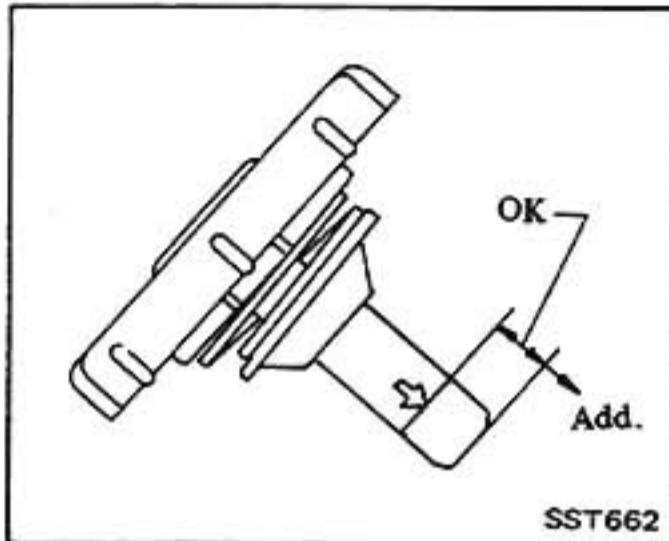

- Do not overfill with fluid.
- Normal operating temperature is 60 to 80°C (140 to 176°F).
- When running engine, make sure fluid level variations in opening oil pump are less than 2 mm (0.08 in).

2. Check fluid level and leakage.

Recommended fluid is Automatic Transmission Fluid "Dexron Type". Refer to Section MA for "Recommended Lubricant".

Fluid capacity (With oil pump, each hose and steering gear assembly):
 Approximately
 750 - 950 ml
 (26.4 - 33.4 Imp fl oz)

Pump belt adjustment

Adjust oil pump belt tension.

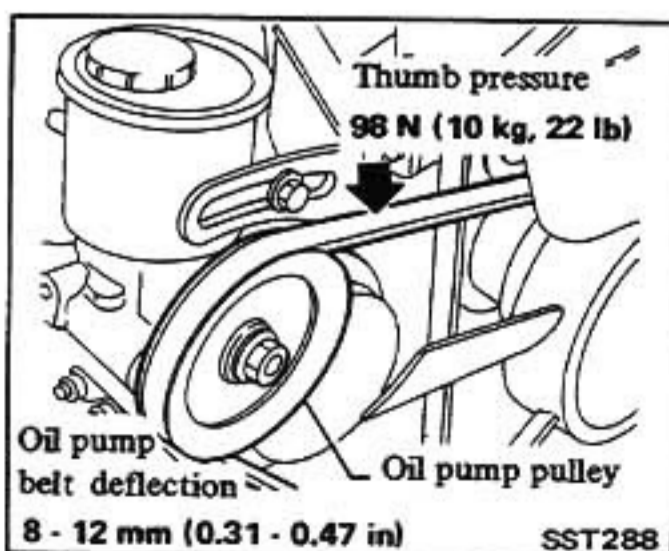

Check fluid leakage

1. Run engine at idle speed or 1,000 rpm.

Make sure temperature of fluid in pump rises to 60 to 80°C (140 to 176°F) with a temperature indicator.

2. Turn steering wheel to right-to-left several times.
3. Hold steering wheel at each "lock" position for five seconds and carefully check the following points for fluid leakage.

- Oil seal at rear cover
- Intermediate cover
- Adjusting screw lock nut
- Sector shaft oil seal
- Sector cover O-ring
- Oil pressure line connectors

CAUTION:

Do not hold steering wheel at lock position for more than fifteen seconds at a time.

Hydraulic system check

To determine whether problem is in steering gear or oil pump, measure operating pressure.

Before conducting hydraulic system test, carefully check belt tension and condition of driving pulley.

Tires must be inflated to normal pressure.

1. Check fluid level and fluid leakage, adding oil if necessary.

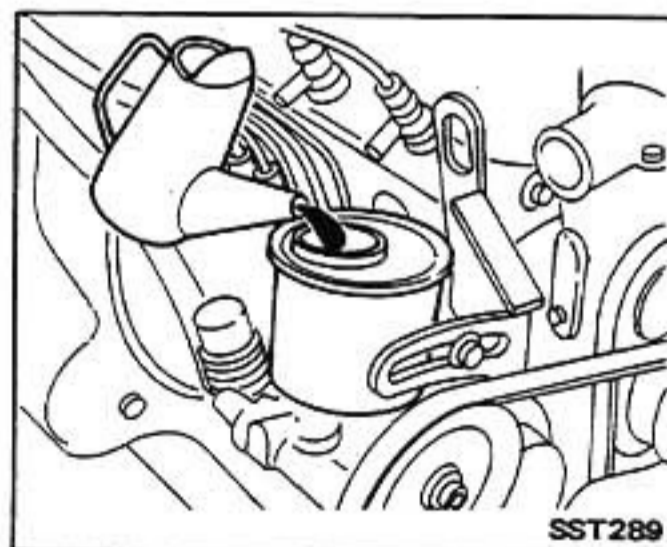

2. Run engine.

Make sure temperature of fluid in pump rises to 60 to 80°C (140 to 176°F) with a temperature indicator.

3. Stop engine.
4. Set Tool.

- Gauge must be between shut-off valve and oil pump.

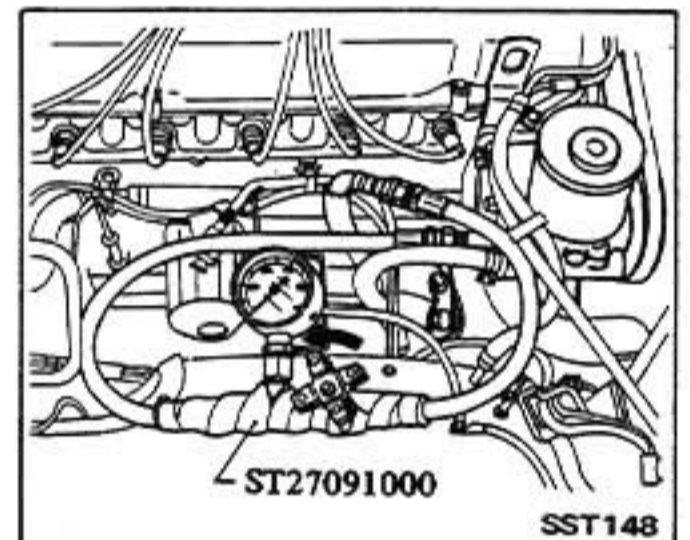
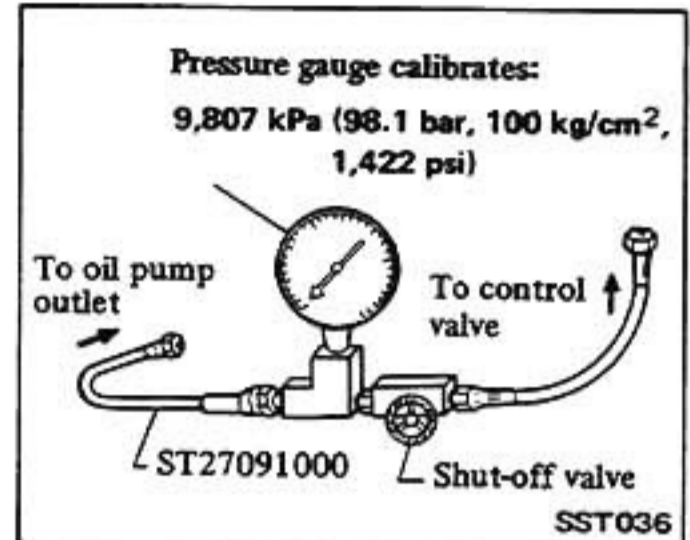

5. Open shut-off valve at Tool.
6. Check fluid level, adding fluid if necessary.
7. Run engine at idle for 3 to 5 seconds.
8. Stop engine and check fluid level, adding fluid if necessary.
9. Run engine and check fluid level again, adding oil if necessary.
10. Turn steering wheel fully in left or right until fluid reaches operating temperature.

- Be sure that all connections are tight.
- Expel any air from system.

11. Slowly close shut-off valve with steering wheel fully turned in left or right and lightly touch wheel stopper.

CAUTION:

Do not close shut-off valve for more than fifteen seconds, as this would abnormally increase lubricant temperature and cause undue pump wear.

With valve fully closed, pump pressure should be at maximum.

Normal pressure:
 6,865 kPa (68.6 bar,
 70 kg/cm², 995 psi) at idling

12. If pressure increases beyond upper limit, pressure relief valve in oil pump is not functioning properly. Replace as oil pump assembly.

13. If, with shut-off valve fully closed, pressure drops below lower limit, the problem is in pump. Replace as oil pump assembly.

After checking hydraulic system, add fluid as necessary, then completely bleed air out of system.

Bleeding hydraulic system

1. Raise front end of vehicle until wheels clear ground.
2. Run engine.

Make sure temperature of fluid in pump rises to 60 to 80°C (140 to 176°F) with a temperature indicator.

3. Check fluid level, adding fluid if necessary.

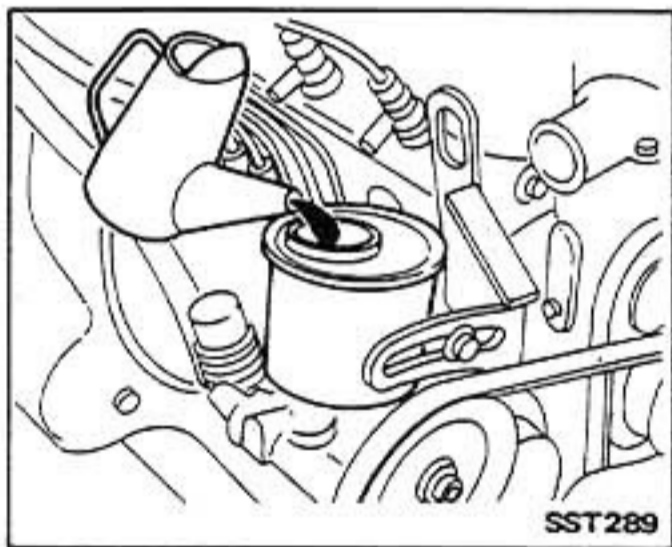

4. Run engine for 3 to 5 seconds.
5. Stop engine, adding fluid if necessary.
6. Quickly turn steering wheel all the way to right and left ten times and lightly touch wheel stoppers.
7. Check fluid level, adding fluid if necessary.
8. Start engine at idle.

Repeat steps 4 through 8 until air will be bled from pump.

9. Stop engine and cool fluid. Check fluid level, adding fluid if necessary.

- Operation should be performed, making sure that fluid level is kept within specified limit.
- Repeat this operation until air bleeding is completed.

10. If air cannot be bled completely in steps 1 through 9, proceed as follows:

- (1) With engine running at 1,000 to 1,500 rpm, repeat step 9.
- (2) Turn steering wheel to right and left from lock to lock five to ten times. Carefully check fluid leakage with steering wheel held at each lock position for five seconds.

CAUTION:

Do not hold steering wheel at lock position for more than fifteen seconds at a time.

Steering wheel turning torque check

1. Park vehicle on a level, dry surface and set parking brake firmly.
2. Bring power steering fluid up to adequate operating temperature. [Approximately 60 to 80°C (140 to 176°F)].

- It is easy to bring power steering fluid up to adequate operating temperature by idling engine and at the same time turning steering wheel from left to right for about two minutes. Alternatively, drive vehicle several miles.
- Tires must be inflated to normal pressure.

3. Check steering wheel turning torque when steering wheel has been turned 360° from straight-ahead position.

Steering wheel turning force:
 Less than 34.3 N (3.5 kg, 7.7 lb)
 at circumference of steering wheel

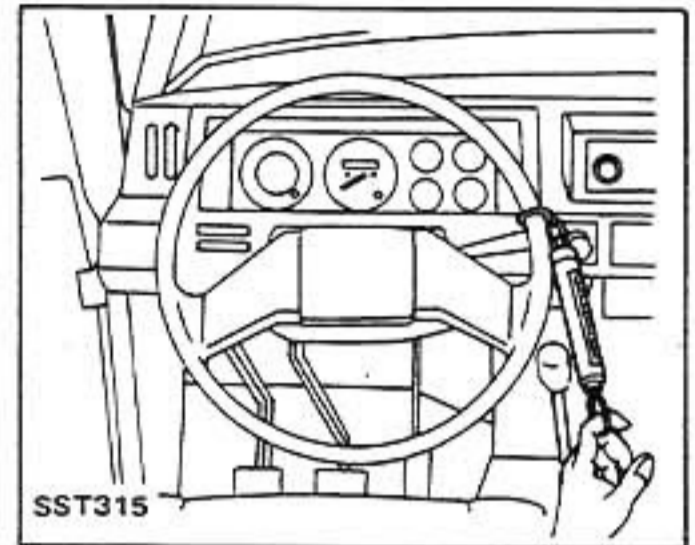

INSPECTION AND ADJUSTMENT

Wash clean all disassembled parts in suitable cleaning solvent and check their condition.

Check sealing portion.

- O-ring at adjusting screw nut
- O-ring at sector shaft cover
- Sector shaft oil seals
- Rear housing oil seal
- O-rings at intermediate cover

Discard any oil seals and O-rings which have once been removed.

Replace oil seal and O-ring if sealing surface is deformed or cracked.

Steering gear turning torque measurement

1. Measure turning torque at 360° position.

- (1) Install steering gear on Tool.

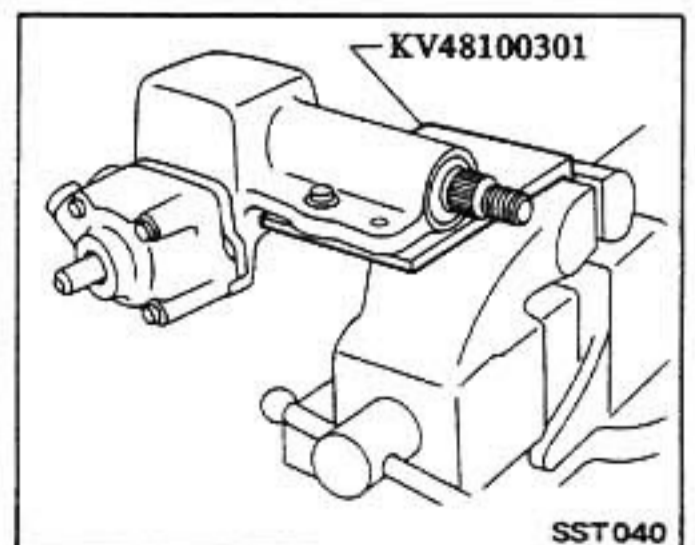

- (2) Turn stub shaft all the way to right and left several times.
- (3) Measure turning torque at 360° position from straight-ahead position using Tool.

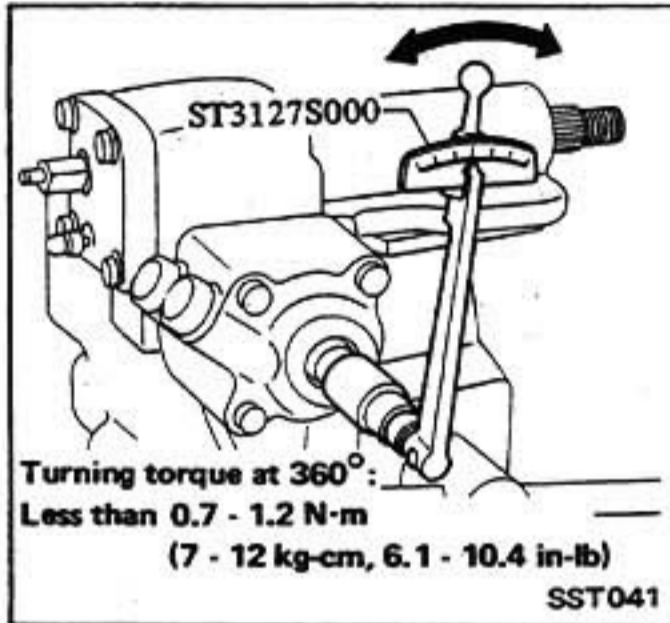

- Stub shaft can be turned by wrapping vinyl tape around serration area of stub shaft and fitting wrench socket.
- If it is beyond specification, gear must be replaced as an assembly.

2. Measure turning torque at straight-ahead position.

(1) Set worm gear in a straight-ahead position.

Straight-ahead position is a position where stub shaft is turned two turns by 45° from lock position.

(2) Measure turning torque using Tool.

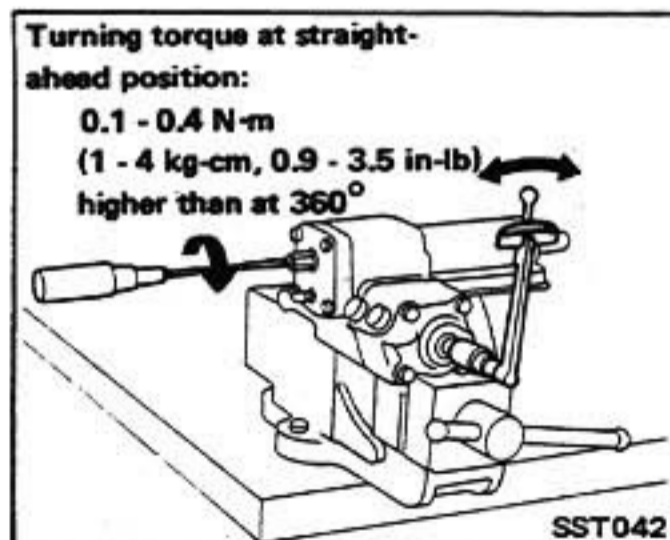

3. After adjustment is completed, tighten lock nut.

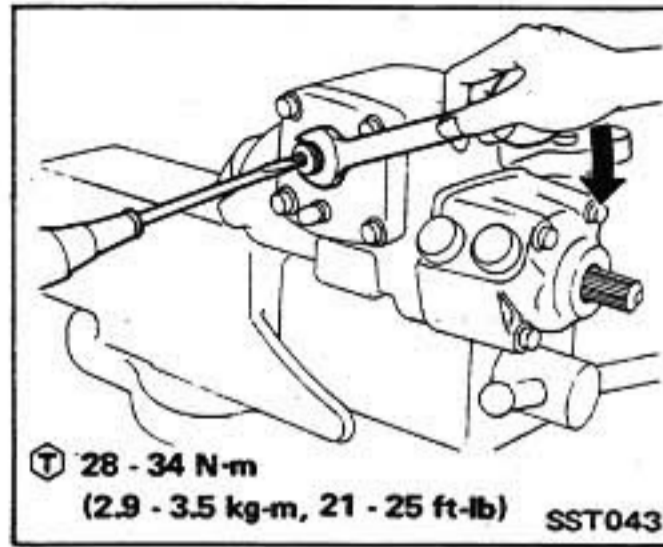

Measure turning torque. If they are not within specifications, replace gear assembly.

DISASSEMBLY

Before disassembly, measure turning torque.

If they are not within specifications, replace steering gear assembly.

CAUTION:

Each oil sealing parts and dust cover once removed must not be used again.

Adjusting screw lock nut seal

Remove adjusting screw lock nut, and replace O-ring.

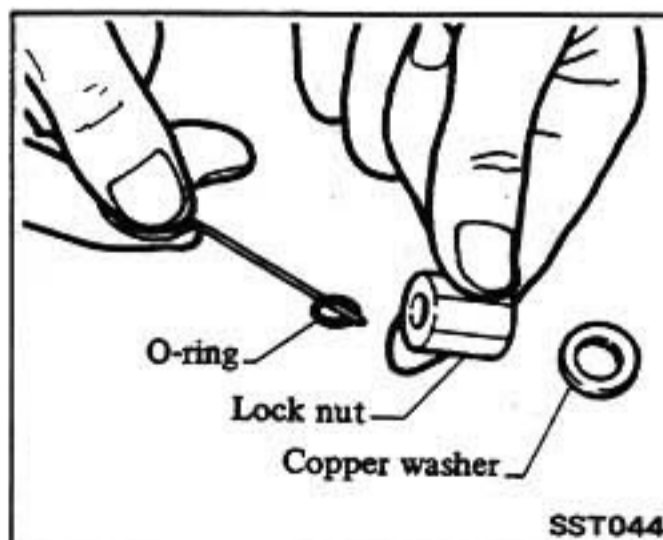

Sector shaft oil seal

1. Install steering gear on Tool KV48100301.
2. Set stub shaft in a straight-ahead position.

Straight-ahead position is a position where stub shaft is turned two turns by 45° from lock position.

3. Disconnect sector shaft cover bolt. Do not loosen adjusting screw lock nut.

Do not turn lock nut unless necessary; otherwise it will damage O-ring, resulting in an oil leak.

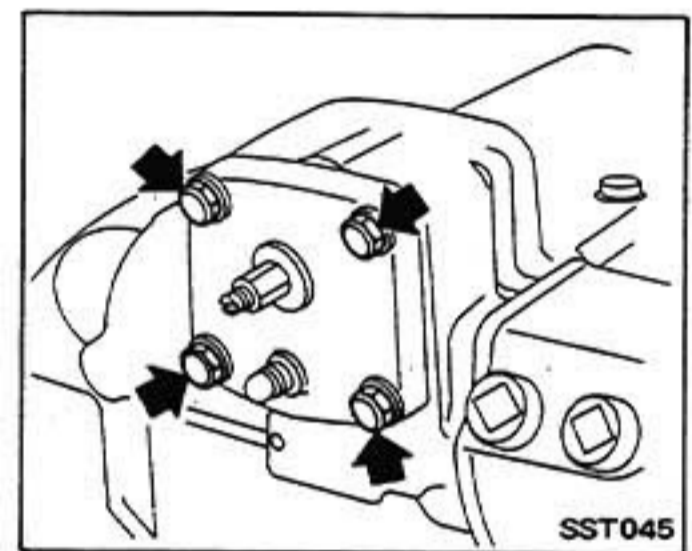

4. Draw out sector shaft.

Knock out end of sector shaft approximately 20 mm (0.79 in).

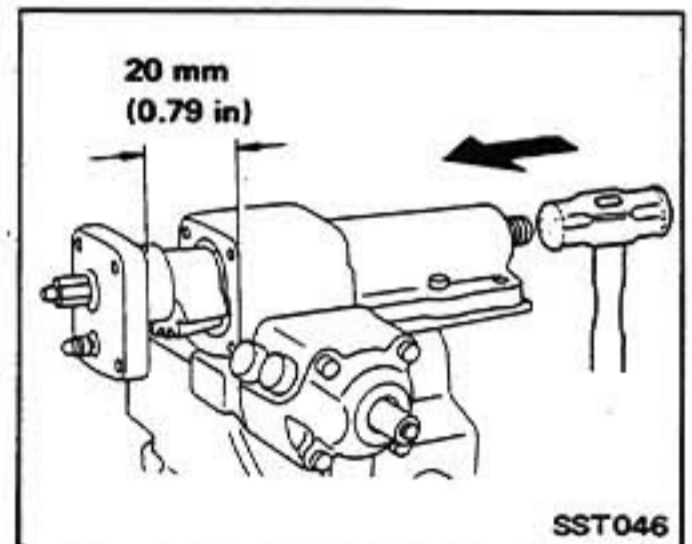

5. Pull out sector shaft by hand.

Attach plastic film to two bearings located inside gear housing while simultaneously pulling out sector shaft so that bearings will not drop into housing.

6. Remove snap ring.

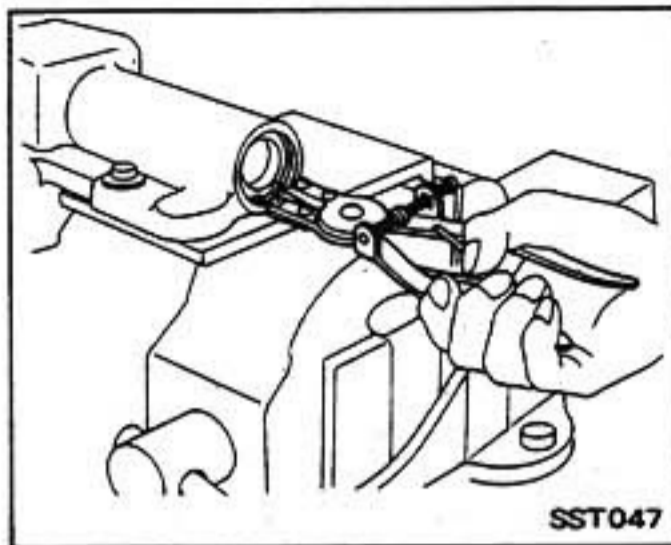

7. Remove dust cover, special washers and oil seal.

Apply blade of screwdriver to oil seal lightly so that it will not damage inner side of gear housing.

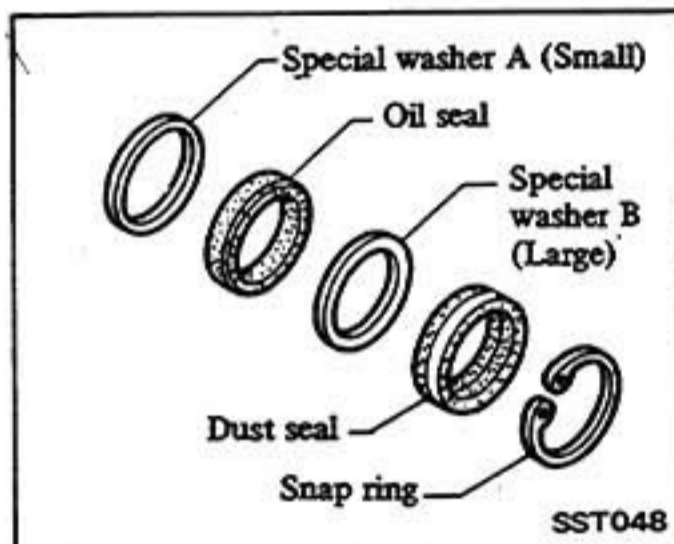

8. Remove O-ring.

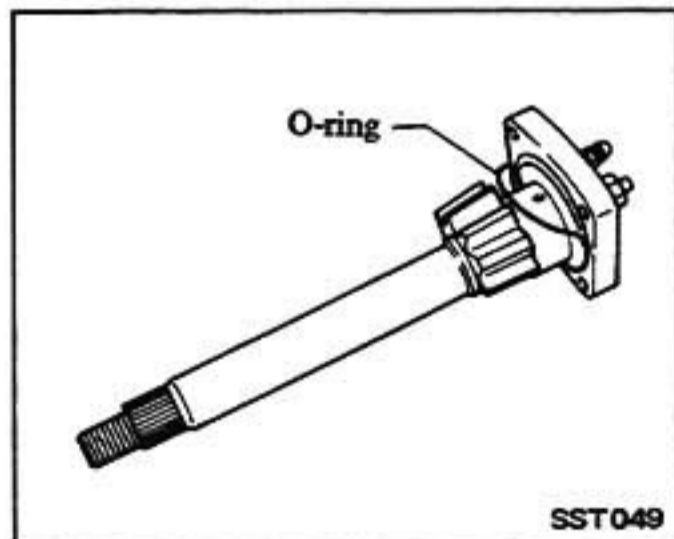

Rear housing seal

1. Install gear on Tool KV48100301 in a vise.
2. Loosen (not remove) rear housing bolts.

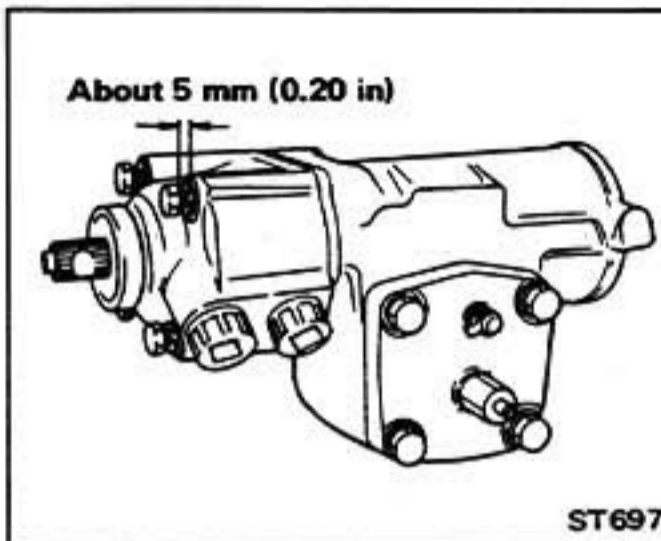

3. Turn sector shaft clockwise slightly to raise intermediate cover through piston.

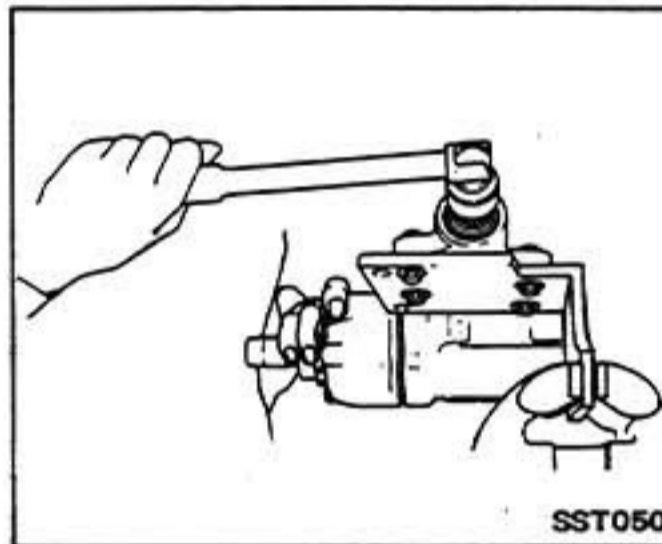

4. Turn stub shaft counterclockwise and place piston (worm gear) in its straight-ahead position.

5. Remove sector shaft.

Refer to Sector Shaft Seal for disassembly.

6. Remove rear housing bolts.

7. Pull out rear housing, intermediate cover with worm gear assembly.

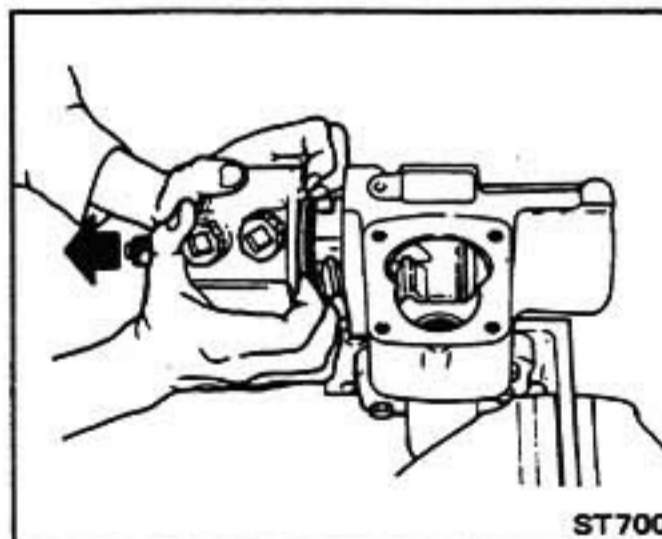

CAUTION:

- a. When worm assembly is removed, piston may turn and come off under its own weight. Hold piston to prevent it from turning.

If piston-to-intermediate cover clearance exceeds 45 mm (1.77 in) by loosening, recirculating ball will be out of groove of worm; do not reinstall piston but replace the entire assembly.

- b. Take care not to damage teflon ring at piston end when removing.

8. Remove rear housing, turn worm assembly upside down, and lightly tap stub shaft end on top of workbench.

CAUTION:

Do not strike shaft with a hammer or pry it with a screwdriver.

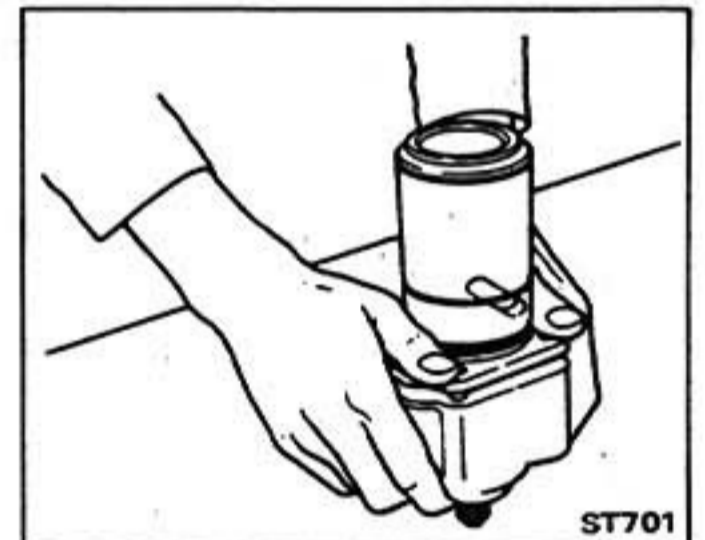

9. Remove rear housing oil seal.

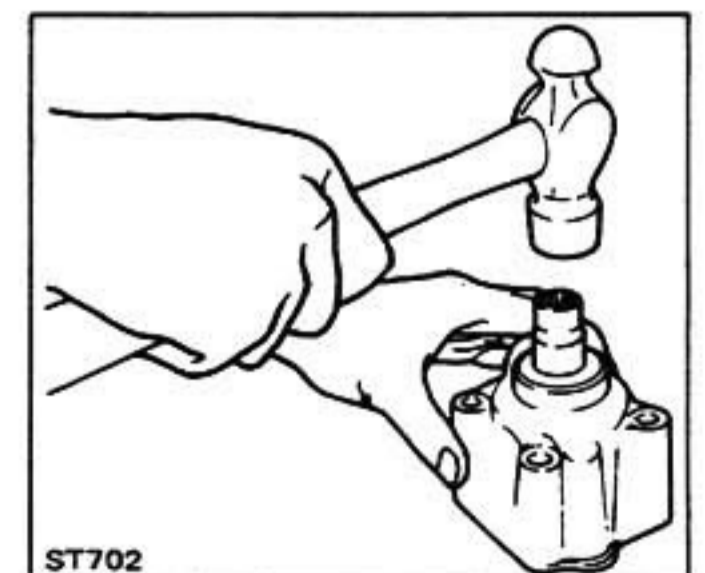

10. Remove O-ring on both sides of intermediate cover.

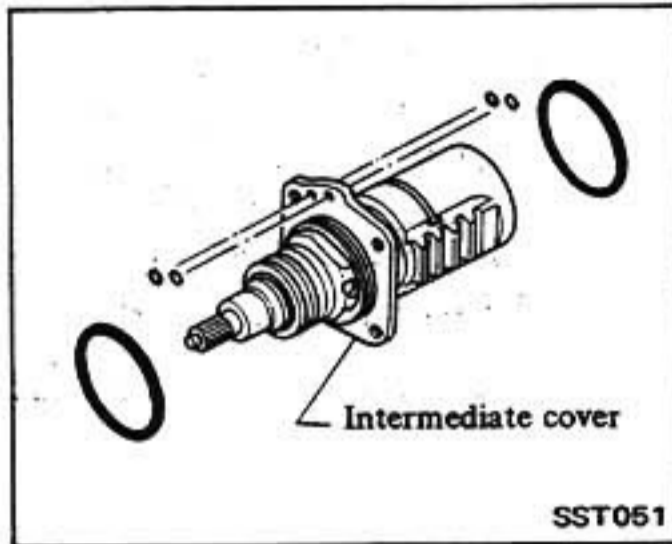

ASSEMBLY

Adjusting screw lock nut seal

Insert new O-ring into adjusting screw lock nut.

- Before inserting, apply a thin coat of vaseline to O-ring.
- Insert O-ring to make sure it fits into groove.

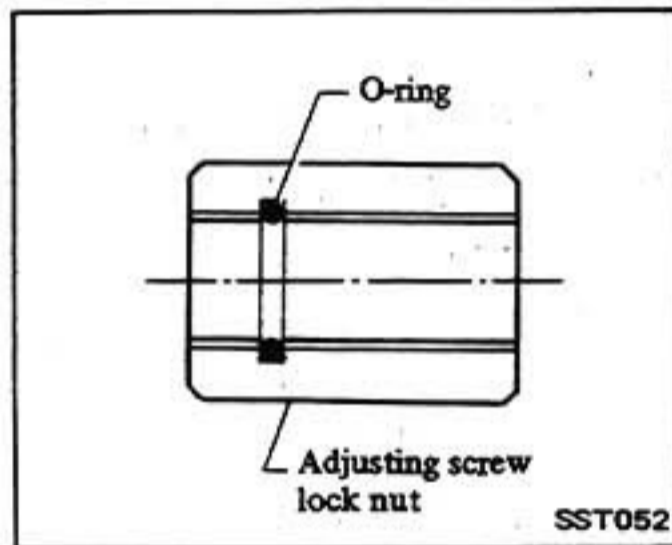

Rear housing seal

1. Install rear housing oil seal using Tool.

Before installing oil seal, apply recommended multi-purpose grease to lips.

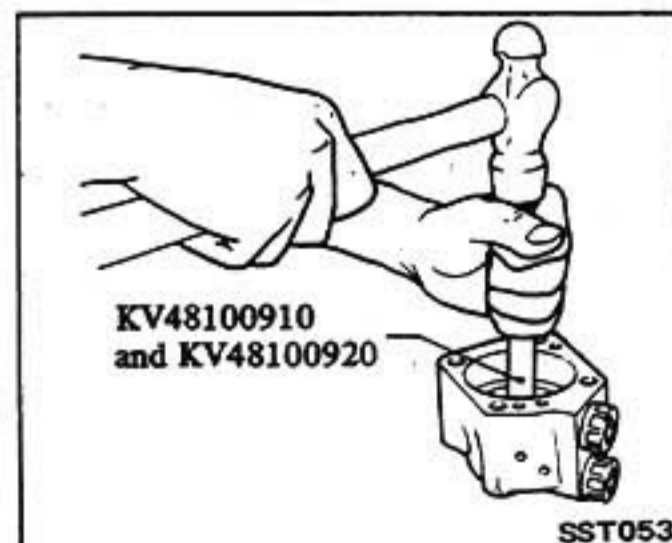

2. Install O-rings on both sides of intermediate cover with new ones.

- Apply a thin coat of vaseline to new O-rings prior to their installation.
- Be careful not to install wrong O-rings as some of them resemble in size.

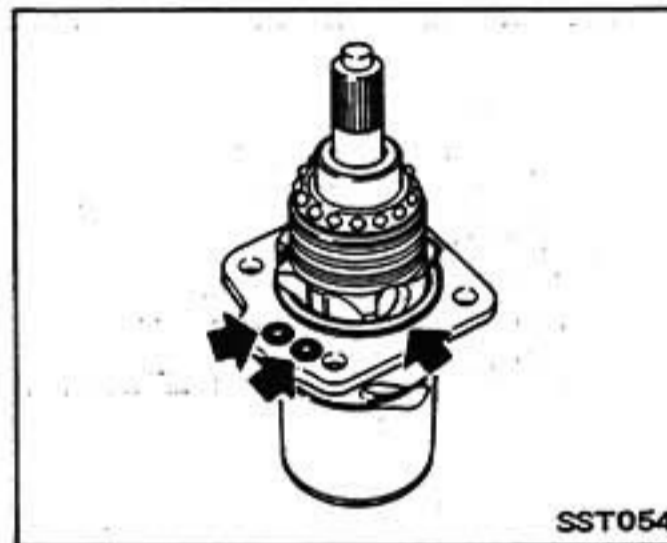

3. Fit rear housing onto intermediate cover with worm gear assembly.

CAUTION:

- a. Do not tilt ball bearing.
- b. Make sure that O-rings are not protruding or extruding.

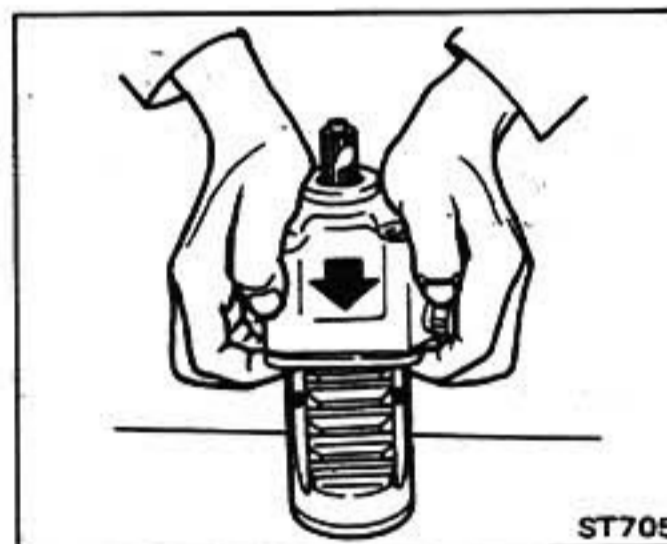

4. Insert worm gear assembly with rear housing and intermediate cover into gear housing

CAUTION:

- a. Be careful that teflon ring at piston end is not damaged during insertion of gear housing.
- b. When worm assembly is halfway inserted, teflon ring is deflected. Insert remaining part of worm assembly paying particular attention. Take care not to damage teflon ring on corner of sector hole. Be sure that teflon ring settles in its correct position.

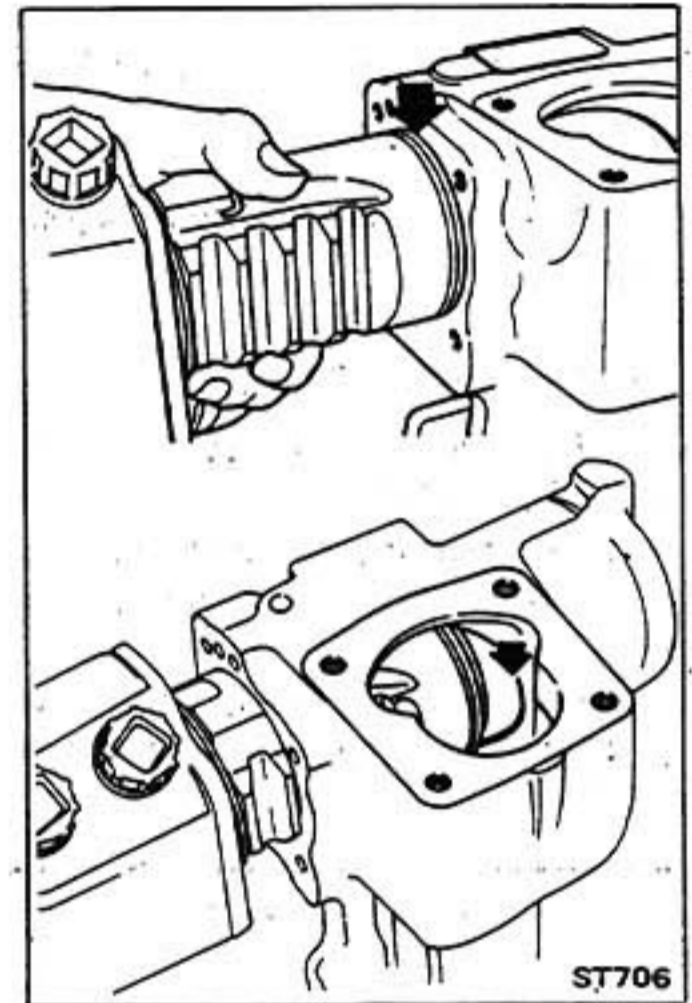

5. Gradually tighten rear housing bolts in a criss-cross fashion.

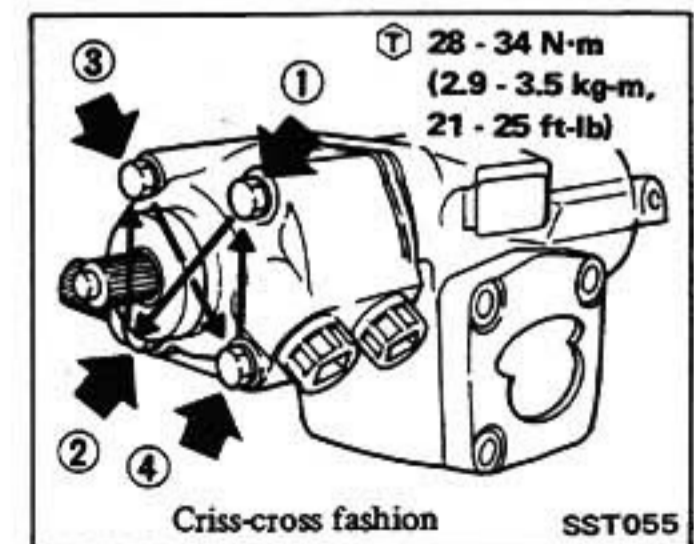

CAUTION:

- a. If bolts are tightened while worm assembly is tilted, inner seals will be damaged. Tighten bolts while assembly is level.
If worm assembly is tilted, stub shaft's turning torque will be increased.
- b. Check O-rings to ensure that they do not protrude or extrude.

- 6. Install sector shaft into gear housing.
Refer to Sector Shaft Oil Seal for assembly.
- 7. Check turning torque.
Refer to Inspection and Adjustment.

Sector shaft oil seal

- 1. Press new oil seal and dust cover using Tool KV481009S0.
- When installing, be sure to use new oil seal, dust cover and special washers.
- Before installing, apply a thin coat of vaseline to new oil seal and dust cover.

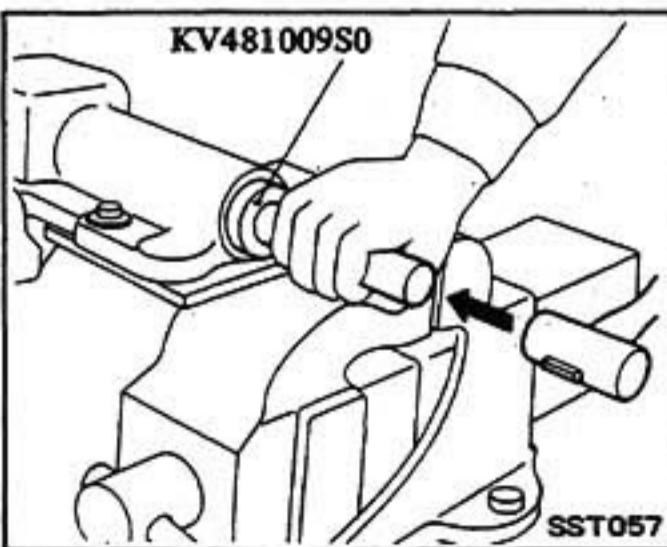
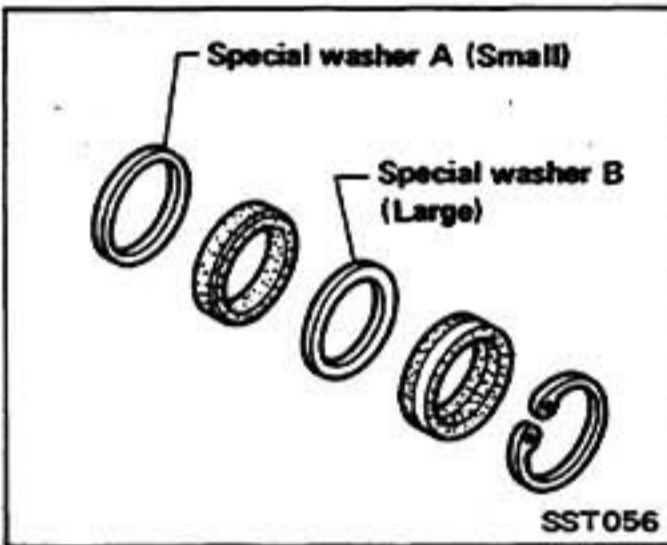

- 2. Install a new snap ring into gear housing.

CAUTION:

- a. Turn snap ring to make sure it fits into groove.
- b. Always install snap ring with its rounded edges facing oil seal.

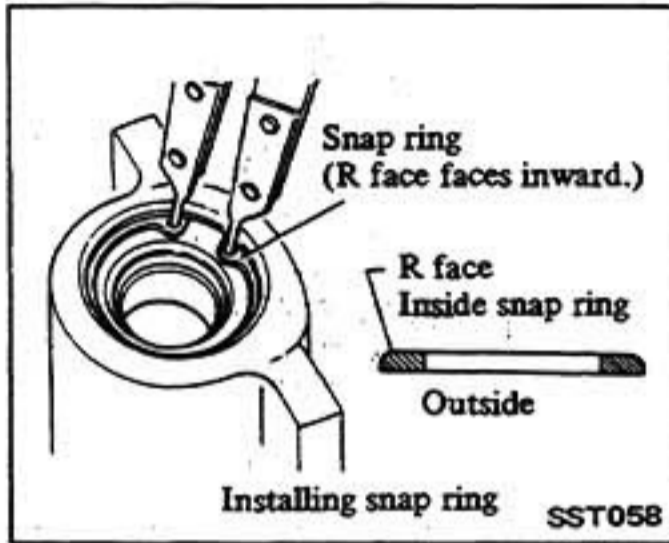

- 3. Fit new O-ring into sector shaft cover.
- Before installing, apply a thin coat of vaseline to O-ring.
- Make certain that O-ring is installed properly, and not damaged by sector shaft.

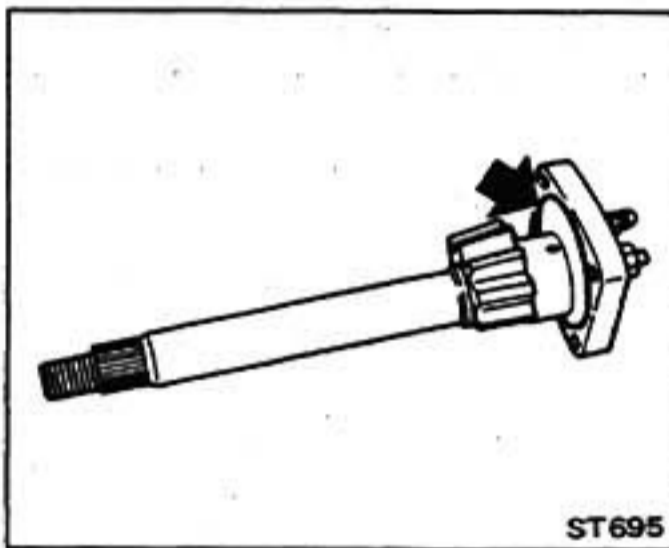

- 4. Set piston rack at straight-ahead position.
Turn piston rack about 10° to 15° toward yourself with your finger.
This is for smooth insertion of sector gear.

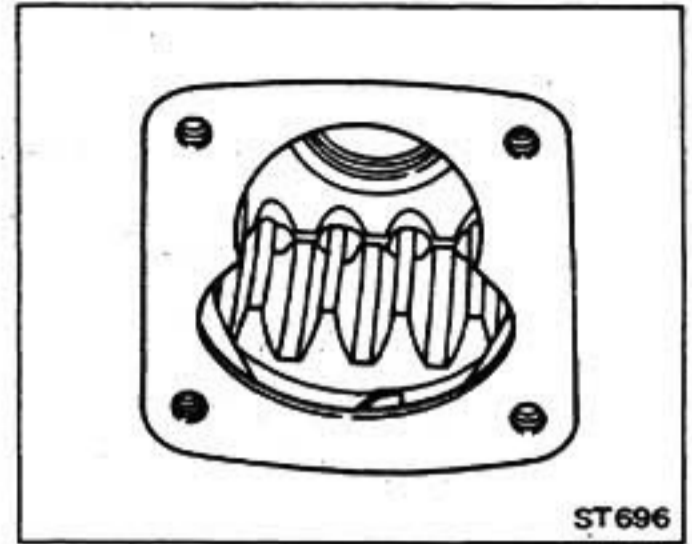

- 5. Wrap vinyl tape around serration area of sector shaft.

The reason is that vinyl tape prevents oil seal lip from being damaged during insertion.

- 6. Gradually insert sector shaft into gear housing, being careful not to damage oil seal.

When inserting sector shaft into gear housing, remove plastic film. Be careful not to drop bearings into gear housing.

- 7. Tighten sector shaft cover bolts.

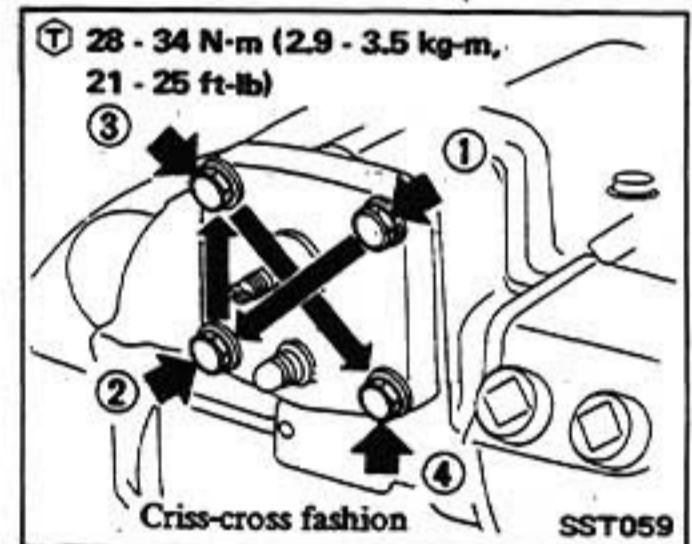

- 8. Check steering gear turning torque.

Refer to Inspection and Adjustment.

- If there is a great difference between values of turning torque before and after disassembly, it must be assumed that some new problem has occurred. It will be necessary to replace the entire assembly.

DISASSEMBLY

Tie rod assembly

1. Remove tie rod assembly from knuckle flange using Tool HT72520000.
2. Separate tie rod socket assembly from tie rod tube.

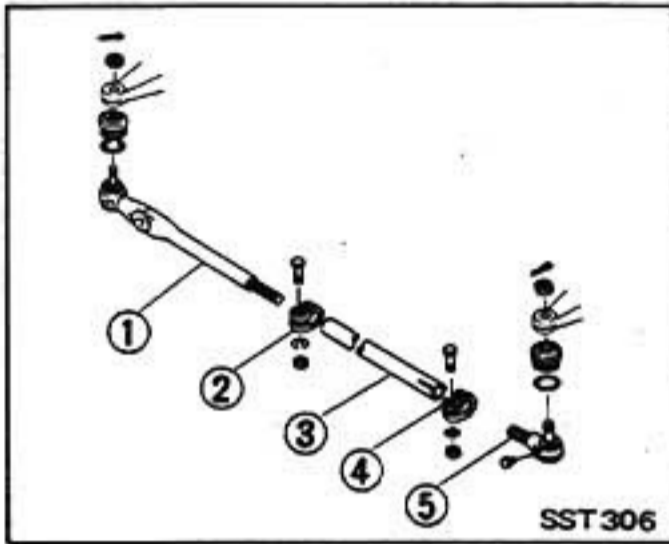

- | | |
|---------------------------|---------------------------|
| 1 Tie rod socket assembly | 4 Tie rod clamp |
| 2 Tie rod clamp | 5 Tie rod socket assembly |
| 3 Tie rod tube | |

Relay lever assembly

Loosen nut, and separate each part.

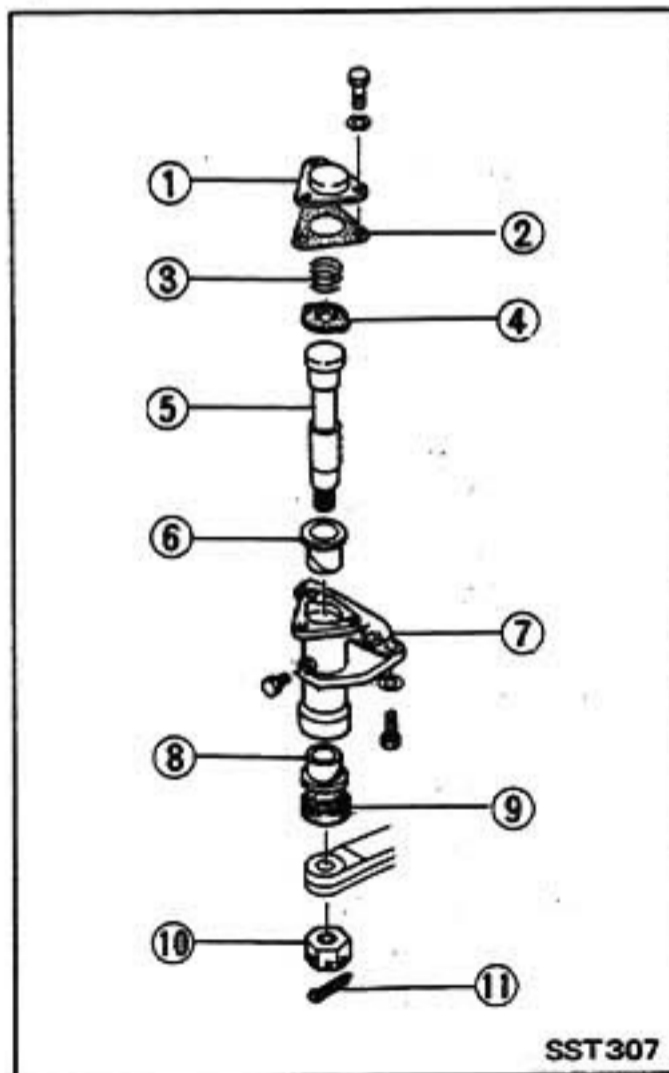

- | | |
|-----------------------------|-----------------------|
| 1 Relay lever bracket cover | 7 Relay lever bracket |
| 2 Gasket | 8 Bushing |
| 3 Spring | 9 Grease seal |
| 4 Spring seat | 10 Nut |
| 5 Relay lever shaft | 11 Cotter pin |
| 6 Bushing | |

ASSEMBLY

Assemble steering linkage in the reverse order of disassembly, observing the following instructions.

Relay lever assembly

- Apply multi-purpose grease to clearance between shaft and bracket, and to each sliding portion.

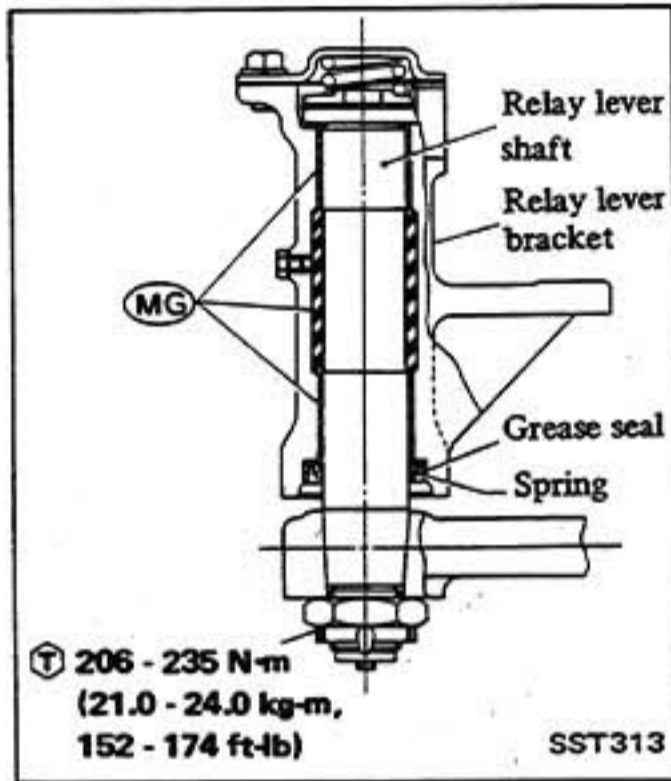

- Press relay lever bushing and grease seal into bracket. Apply multi-purpose grease between lips of grease seal.
- Apply liquid packing to both sides of gasket, and install relay lever bracket cover.

Ⓣ : Relay lever starting torque
Less than 4.9 N·m
(50 kg·cm, 43 in·lb)

Tie rod assembly

When tie rod socket assembly and tie rod tube are separated, correctly adjust tie rod length.

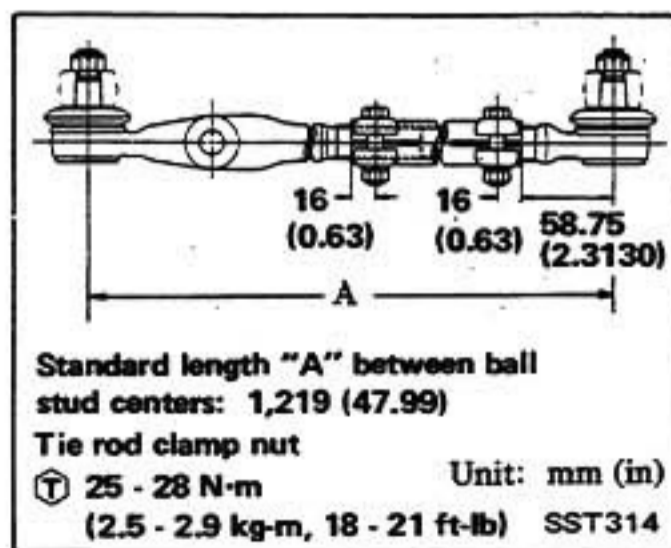

INSPECTION

Ball joint

1. When ball stud is worn or axial play exists, replace side rod socket with a new one.
2. When dust cover is broken or deformed, be sure to replace with a new one (rod assembly).

Initial turning torque:

Ball joint
1.0 - 4.9 N·m
(10 - 50 kg·cm,
8.7 - 43.4 in·lb)

Relay lever assembly

Check grease seal for breakage, wear or play, and if necessary replace.

Initial turning torque:

Less than 4.9 N·m
(50 kg·cm, 43 in·lb)

Tie rod assembly

Check tie rod socket assembly and tie rod tube for breakage, bend or crack, and replace with a new one if necessary.

Steering damper

Check oil leakage or damping force of damper, and replace if necessary.

Damping force:

Except for Australia
147 N (15 kg, 33 lb)
at 0.3 m (1.0 ft)/sec.

For Australia
657 - 912 N
(67 - 93 kg,
148 - 205 lb) at
0.3 m (1.0 ft)/sec.

Fixing location

Check fixing location (nuts and cotter pins) for looseness, play or breakage. When looseness or play is found, check for wear on tapered portion of ball stud, pitman arm or relay lever assembly.

When reassembling each ball joint, use new cotter pins.

SERVICE DATA AND SPECIFICATIONS

GENERAL SPECIFICATIONS

Steering column type	Europe (Except pick-up)	Collapsible	
	Middle East Except above	Solid	
Steering gear model	VRB70L	IPS56L	
Turns of steering wheel on the vehicle (Lock-lock)	4.5	3.6	
Steering gear ratio	24.4 - 26.84	17.0	
Steering damper	N (kg, lb)	147 (15, 33)	

INSPECTION AND ADJUSTMENT

Front wheel full turning angle	Inner wheel	degree	28° - 30°
	Outer wheel	degree	27.5° - 29.5°
Minimum turning radius (Wall to wall)	m (ft)	Hardtop	5.5 (18.0)
		Pick-up	6.7 (22.0)
		Canvas Top	5.8 (19.0)
Steering wheel axial play	mm (in)	0 (0)	
Steering wheel play	mm (in)	Less than 35 (1.38)	

STEERING GEAR

Model VRB70L

Worm bearing preload (With oil seal)	0.39 - 0.59 (4.0 - 6.0, 3.5 - 5.2)		
Worm bearing preload adjusting shims			
Standard shim thickness	mm (in)	1.0 (0.039)	
Adjusting shim thickness	Thickness	mm (in)	Unit number
		0.500 (0.0197)	48273 82100
		0.200 (0.0079)	48274 82100
		0.100 (0.0039)	48275 82100
		0.075 (0.0030)	48276 82100
		0.050 (0.0020)	48277 82100
Steering gear total preload (With oil seal)	Less than 1.23 N-m (12.5 kg-cm, 10.9 in-lb)		

Backlash at gear arm top end (In straight-ahead position)	0 - 0.2 (0 - 0.008)	
End play (Between sector shaft and adjusting screw)		
Standard shim thickness	mm (in)	0.01 - 0.03 (0.0004 - 0.0012)
Adjusting shim thickness	Thickness	Part number
	1.575 - 1.600 (0.0620 - 0.0630)	48213 B0100
	1.550 - 1.575 (0.0610 - 0.0620)	48214 B0100
	1.525 - 1.550 (0.0600 - 0.0610)	48215 B0100
	1.500 - 1.525 (0.0591 - 0.0600)	48216 B0100
	1.475 - 1.500 (0.0581 - 0.0591)	48217 B0100
	1.450 - 1.475 (0.0571 - 0.0581)	48218 B0100
Oil capacity liters (Imp pt)	Model 160 series	Approximately 0.40 (3/4)
	Model 61 series	Approximately 0.45 (3/4)

Model IPS 56L

Oil pump belt deflection	mm (in)	8 - 12 (0.31 - 0.47) at 98N (10 kg, 22 lb)
Steering wheel turning force (At circumference of steering wheel)	N (kg, lb)	Less than 34.3 (3.5, 7.7)
Oil pump maximum pressure	kPa (bar, kg/cm ² , psi)	6,865 (68.6, 70, 995) at idling
Normal operating temperature at fluid	°C (°F)	60 - 80 (140 - 176)
Fluid capacity	mℓ (Imp fl oz)	Approximately 750 - 950 (26.4 - 33.4)
Steering gear turning torque	N-m (kg-cm, in-lb)	0.7 - 1.2 (7 - 12, 6.1 - 10.4)
	360° position from straight-ahead position	
	Straight-ahead position (As compared with steering wheel turned 360°)	0.1 - 0.4 (1 - 4, 0.9 - 3.5) higher than at 360°

STEERING LINKAGE

	N-m	kg-cm	in-lb
Initial turning torque Ball joint	1.0 - 4.9	10 - 50	8.7 - 43.4
Relay lever	Less than 4.9	Less than 50	Less than 43

TIGHTENING TORQUE

STEERING COLUMN (Model 160 series)

	N-m	kg-m	ft-lb
Steering wheel nut	39 - 49	4.0 - 5.0	29 - 36
Jacket tube bracket to dash panel	3.4 - 4.4	0.35 - 0.45	2.5 - 3.3
Steering column mount- ing bracket	13 - 18	1.3 - 1.8	9 - 13
Stub shaft or worm shaft to coupling	39 - 49	4.0 - 5.0	29 - 36

STEERING GEAR

	VRB70L			IPS56L		
	N-m	kg-m	ft-lb	N-m	kg-m	ft-lb
Pitman arm nut	235 - 265	24.0 - 27.0	174 - 195	137 - 177	14 - 18	101 - 130
Steering gear housing to body frame	84 - 96	8.6 - 9.8	62 - 71	84 - 96	8.6 - 9.8	62 - 71
Sector shaft cover to gear housing	15 - 25	1.5 - 2.5	11 - 18	28 - 34	2.9 - 3.5	21 - 25
Rear cover to gear housing	31 - 36	3.2 - 3.7	23 - 27	23 - 32	2.3 - 3.3	17 - 24
Sector shaft adjusting screw lock nut	29 - 39	3.0 - 4.0	22 - 29	28 - 34	2.9 - 3.5	21 - 25
Oil pump to bracket	—	—	—	26 - 36	2.7 - 3.7	20 - 27
Hose to oil pump	—	—	—	29 - 49	3.0 - 5.0	22 - 36
Steering gear to hoses	—	—	—	39 - 49	4.0 - 5.0	29 - 36

STEERING LINKAGE

	N-m	kg-m	ft-lb
Ball stud nuts	46 - 54	4.7 - 5.5	34 - 40
Tie rod adjusting tube clamp nuts	64 - 78	6.5 - 8.0	47 - 58
Relay lever nut	206 - 235	21.0 - 24.0	152 - 174
Relay lever assembly to body frame	45 - 52	4.6 - 5.3	33 - 38

TROUBLE DIAGNOSES AND CORRECTIONS

Except for the following probable causes and corrective actions, refer to Trouble Diagnoses and Corrections in Front Axle and Front Suspension section.

MANUAL STEERING



Condition	Probable cause	Corrective action
Excessive wheel play.	Insufficiently tightened or improperly installed steering gear housing. Damaged steering linkage or ball joint. Incorrect adjustment of steering gear.	Retighten. Replace faulty parts. Adjust.
Vibration, shock or shimmying of steering wheel.	Insufficiently tightened or improperly installed steering gear housing. Wear of steering linkage. Damaged relay lever assembly. Worn column bearing, weakened column bearing spring, or loose clamp.	Retighten. Replace faulty parts. Replace. Replace or retighten.
Vehicle pulls to right or left.	Deformed steering linkage and/or suspension link.	Replace.
Stiff or heavy steering wheel.	Insufficient lubricants or mixing impurities in steering linkage or excessively worn steering linkage. Worn or damaged steering gear and bearing. Incorrectly adjusted steering gear. Deformed steering linkage. Interference of steering column with turn signal switch.	Replenish grease or replace the part. Replace. Adjust. Replace. Adjust.

Trouble Diagnoses and Corrections — **STEERING SYSTEM**

POWER STEERING

Condition	Probable cause	Corrective action
Oil pressure does not build up.	Pump drive belt slipping on pulley. Pump malfunctioning. Oil leaking through hose joints. Oil leaking through power steering.	Readjust belt tension. Replace. Replace or retighten copper washer. Replace sealing parts at steering gear.
Steering wheel moves heavily.	Lack of oil in oil pump.* Air present in oil. Oil pressure too low. Wheel alignment out of specifications or air pressure in tires too low.* Steering gears improperly engaged.* Steering column out of alignment.* Worn or damaged ball joint at suspension and steering linkage.* Relay lever dragging.*	Refill. Bleed air. See "Hydraulic system check". Re-align or inflate tires to correct pressure. Replace gear assembly. Repair or replace. Replace. Repair or replace.
Steering wheel fails to return.	Refer to items marked "*" above. Front wheel caster improperly adjusted. Internal gears dragged or gouged.	Readjust. Replace gear assembly.
Steering effort is not the same in both directions.	Oil leakage in steering gear. Stuffy oil passage in steering gear.	Replace sealing parts. Replace gear assembly.
Unstable running.	Wheel bearing not properly adjusted. Stuck or damaged control valve in steering gear. Front wheel alignment not properly. Excessive steering gear play. Play at suspension and linkage ball joint.	Readjust. Replace gear assembly. Readjust. Readjust backlash or replace gear assembly. Replace.
Noisy pump.	Lack of oil in oil pump. Hoses or oil filter clogged. Loose pulley. Belt noisy or slapping. Broken pump part.	Refill. Clean or, if necessary, replace. Repair. Readjust tension. Replace.

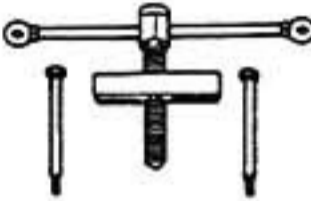
SPECIAL SERVICE TOOLS

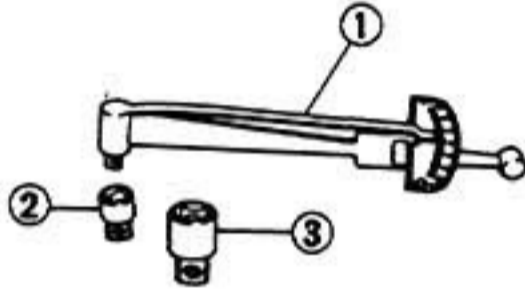
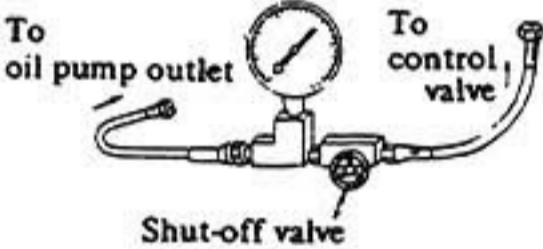
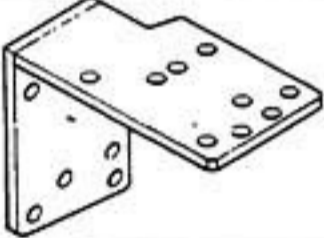
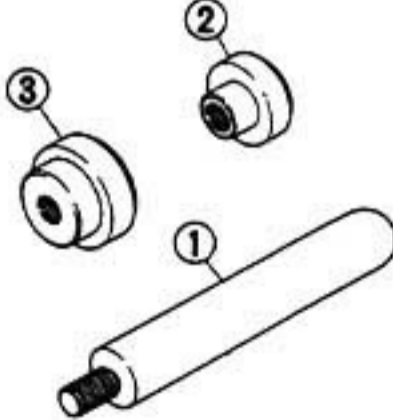
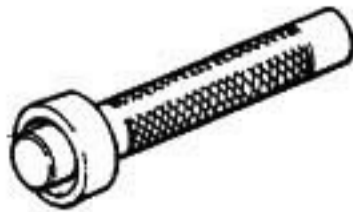
Tool number	Tool name	Unit application	
		Model VRB70L	Model I.P.S. 56L
ST29020001	Steering gear arm puller 	X	X
ST27180001	Steering wheel puller 	X	X
HT72750000	Steering ball joint remover 	X	X
ST3127S000 ① GG91030000 ② HT62900000 ③ HT62940000	Preload gauge Torque wrench Socket adapter Socket adapter 	X	X
ST27091000	Pressure gauge 		X
KV48100301	Steering gear housing attachment 	X	X
KV481009S0 ① KV48100910 ② KV48100920 ③ KV48100930	Oil seal drift set Drift Adapter Adapter 		X
ST33210000	Gear carrier side bearing drift 	X	